



HIGH PRECISION CURRENTY TYPE INCLINOMETER
HCA518T/HCA528T-N
Technical Manual



RION QUALIFICATION CERTIFICATION

- Quality management system certification: GB/T19001-2016 idt ISO19001:2015 standard (Certificate No.: 128101)
- Quality management system certification: IATF16949: 2016 (Certificate No.: T178487)
- Intellectual property management system certification: GB/T29490-2013 standard (Certificate No.: 41922IP00281-06R0M)
- High-tech Enterprise (Certificate No.: GR201844204379)
- Chinese National Intellectual Property Appearance Patent (Patent No .: ZL 201830752890.0)
- Date of revision: 2022-8-31

Note: The product functions, parameters, appearance, etc. will be adjusted with the technical upgrade.
Please contact our pre-sales business to confirm when purchasing.



► GENERAL DESCRIPTION

HCA518T/HCA528T-N is a high accuracy single /dual axis inclinometer, output adopt the standard industry electronic interface 4 ~ 20mA, can be long-distance transmission of up to 2000 meters. The product uses the latest MEMS high technology for production, made precise compensation and correction to temperature error and nonlinearity error, small measuring range and the highest accurate up to 0.003 ° (bigger measuring range index, please refer to product technical data),

HCA518T&HCA528T inclinometer use the dynamic zero test compensation technology to ensure product Quick Launch, high resolution ,stable data, good capacity to bear shock & vibration, built-in anti-RF, adopts anti-electromagnetic interference circuit to ensure that the output signal to a higher anti-interference ,in addition to this product is better than the similar market product on software technical data, on the reliability and stability the product is also using the high-end application-level MCU,three-proofing PCB board, imported cable, wide temperature shielded metal enclosure and other measures to improve product industrial level,to ensure the product can be long-term & safety extraordinary operation in harsh environments.

► FEATURES

- ★ Single / dual axis inclination measurement
- ★ Accuracy: Refer to technical data
- ★ Output mode 4~20mA
- ★ IP67 protection
- ★ High resolution 0.001 °
- ★ Range $\pm 1 \sim \pm 60$ ° optional
- ★ Wide voltage input 11.5 ~ 36V
- ★ Wide temperature operation -40 ~ + 85 °C
- ★ High vibration resistance > 2000g
- ★ Small size L90mm × W59mm × H34mm (customizable)

► APPLICATION

- ★ Equipment vehicle leveling
- ★ High-altitude platform safety protection
- ★ Attitude navigation of underground drilling rig
- ★ Direction measurement based on tilt angle
- ★ Mining machinery, oil drilling equipment
- ★ Alignment control , curve control
- ★ Pitch angle measurement of directional satellite communication antenna
- ★ Bridge and Dam monitoring
- ★ Angle control of medical equipment
- ★ Leveling of railway gauge and gauge
- ★ Tilt monitoring of geological equipment
- ★ Equipment level control

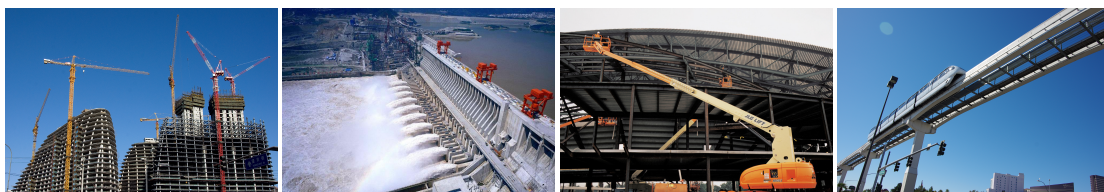

► SPECIFICATIONS

| HCA518T/HCA528T-N | | CONDITION | PARAMETERS | | | | UNIT |
|-------------------------------|------|-------------|---|--------|--------|--------|----------|
| Measure range | | | ±10 | ±30 | ±60 | ±90 | ° |
| Measure axis | | | X/XY | X/XY | X/XY | X/XY | axis |
| Zero output | | 0° output | 12 | 12 | 12 | 12 | mA |
| Resolution | | | 0.001 | 0.001 | 0.001 | 0.001 | ° |
| Measure accuracy | MAXE | Room temp. | 0.005 | 0.01 | 0.02 | 0.03 | ° |
| | RMSE | Room temp. | 0.003 | 0.003 | 0.005 | 0.008 | ° |
| Zero Temp. coefficient | | -40 ~ 85 °C | 0.0005 | 0.0005 | 0.0005 | 0.0005 | % / °C |
| Sensitivity temp. coefficient | | -40 ~ 85 °C | ≤100 | ≤100 | ≤100 | ≤100 | ppm / °C |
| Power on time | | | 0.5 | 0.5 | 0.5 | 0.5 | S |
| Sensitivity temp. coefficient | | | 20Hz | | | | |
| EMC | | | According to EN61000 and GBT17626 | | | | |
| MTBF | | | ≥50000 hours/times | | | | |
| Insulation Resistance | | | ≥100MΩ | | | | |
| Shockproof | | | 100g@11ms、3 Axial Direction (Half Sinusoid) | | | | |
| Anti-vibration | | | 10grms、10 ~ 1000Hz | | | | |
| Protection glass | | | IP67 | | | | |
| Cables | | | Standard configuration: 2m length, wear-resistant, wide temperature, shielded cable 7P * 6.8mm aviation connector, cable weight ≤110g | | | | |
| Weight | | | ≤250g(Excluding cable) | | | | |

*This parameter only list ± 10 °, ± 30 °, ± 60 ° series for reference. For other measurement ranges, please refer to the nearest neighbor parameter.

KEY WORDS

Resolution: Refers to the sensor in measuring range to detect and identify the smallest changed value.

MAXE: refers to the biggest error of the product within the range and at multiple angle points.

RMSE: refers to the root mean square difference between the measured value and the actual angle of the product within the range and for multiple times (more than 16 times).

Zero Temperature Drift Coefficient: the change rate of the indication value relative to normal temperature within the rated operating temperature range of the sensor at the zero degree.

Sensitivity Temperature Drift Coefficient: The percentage change rate with temperature of the full-scale indication relative to the full-scale indication at room temperature of the sensor in its rated operating temperature range.

► ELECTRONIC CHARACTERISTICS

| PARAMETERS | CONDITIONS | MIN | STANDARD | | MAX | UNIT |
|---------------------|------------|------|----------|----|------|------|
| Power supply | Standard | 11.5 | 12 | 24 | 36 | V |
| Working current | No load | | 40 | | | mA |
| Output load | Resistive | | 400 | | 1000 | kΩ |
| Working temperature | | -40 | | | +85 | °C |
| Store temperature | | -40 | | | +85 | °C |

► ORDER INFORMATION

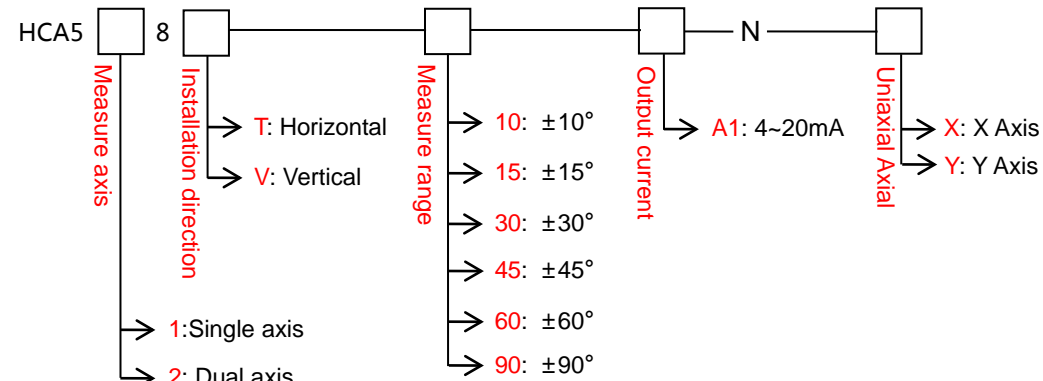

E.g:HCA518T-10-A1-N-X:Single / standard horizontal measurement/±10°measure range /4-20mA output /X Axis.

► MECHANICAL PARAMETERS

- Connector: aviation connector
(1m Direct Leading Cable can Be Customized)
- Protection level: IP67
- Shell material: aluminum alloy shield oxidation
- Installation: Three M4 screws

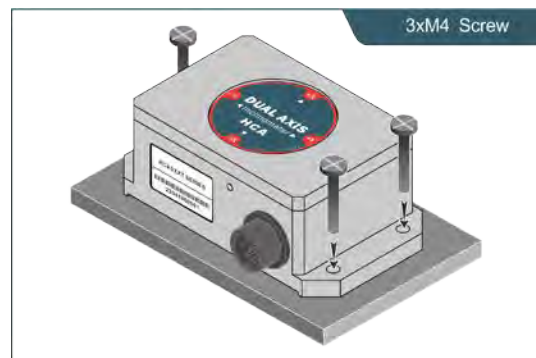

► WORKING PRINCIPLE

Adopt the import of core control unit, using the capacitive micro pendulum principle and the earth gravity principle, when the the inclination unit is tilted, the Earth's gravity on the corresponding pendulum will produce a component of gravity, corresponding to the electric capacity will change,, by enlarge the amount of electric capacity , filtering and after conversion then get the inclination

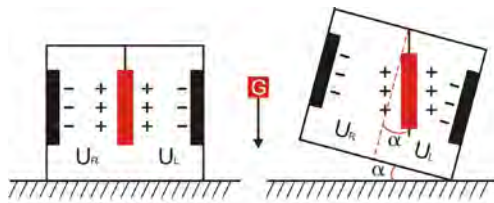

U_R, U_L respectively is the pendulum left plate and the right plate corresponding to their respective voltage between the electrodes, when the tilt sensor is tilted, U_R, U_L will change according to certain rules, so $f(U_R, U_L)$ On the inclination of α function:

$$\alpha = f(U_R, U_L)$$

► ANGLE OUTPUT CALCULATION FORMULA

Angle=(output current-Zero position current)÷Angle sensitivity

Angle sensitivity=output current range÷ Angle measuring range

E.g : HCA518T-30-A1-N (±30° measure range 16mA output voltage range)

$$\text{Angle sensitivity} = 16 \div 60 = 0.266666 \text{ mA}^\circ$$

▶ ELECTRICAL CONNECTION

Single axis cable wire connection :

| Wire Color | RED | WHITE | GREEN | BLACK | GRAY |
|------------|--|-----------------------------------|-------|-----------------------|---------------|
| function | DC11.5~36V Power supply positive | Out X X axis output current | NC | GND Power negative | Signal ground |

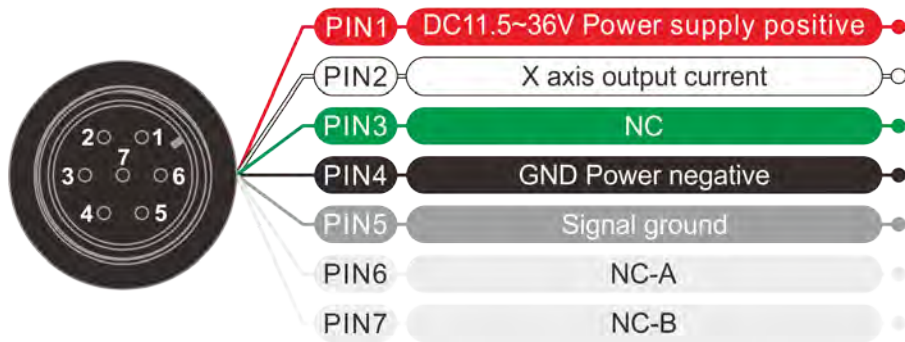

Dual axis cable wire connection :

| Wire Color | RED | WHITE | GREEN | BLACK | GRAY |
|------------|--|-----------------------------------|-----------------------------------|-----------------------|---------------|
| function | DC11.5~36V Power supply positive | Out X X axis output current | Out Y Y axis output current | GND Power negative | Signal ground |

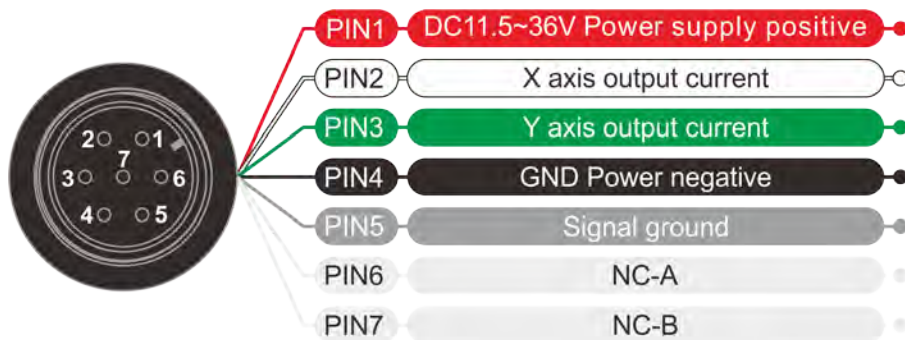

► DIMENSION

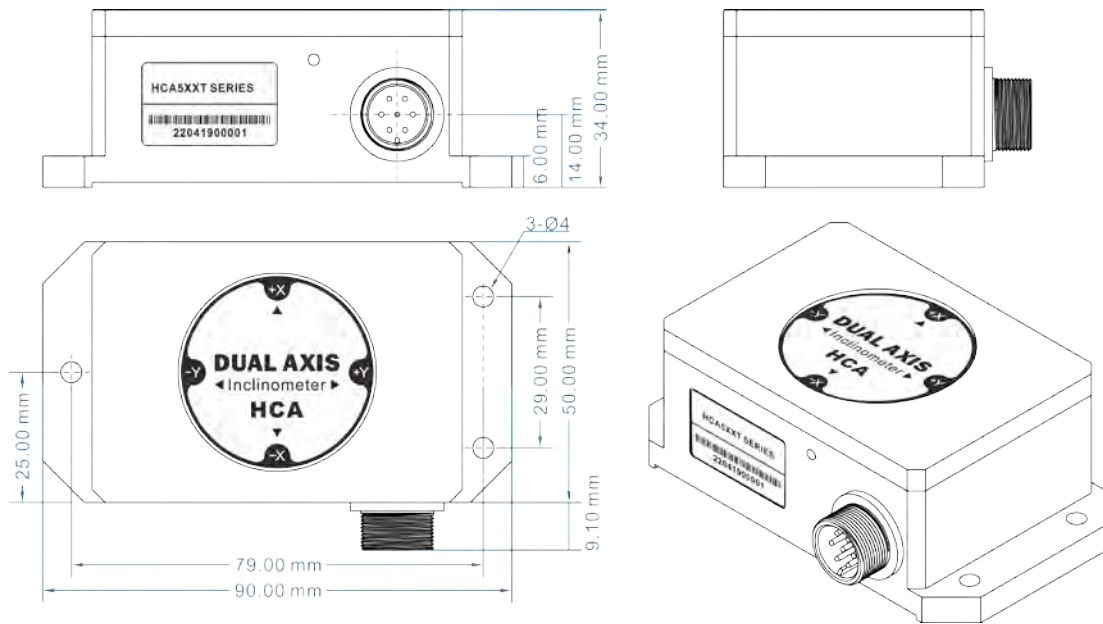

Shell size: L90×W59×H34mm

Installation size: L79×W29×H6mm

Mounting screws: 3M4 screws

► PRODUCTION INSTALLATION NOTES

Please follow the correct way to install tilt sensor, incorrect installation can cause measurement errors, with particular attention to the "surface", "line".

- 1) The Sensor mounting surface and the measured surface must be fixed closely, smoothly, stability, if mounting surface uneven likely to cause the sensor to measure the angle error.
- 2) The sensor axis and the measured axis must be parallel, the two axes do not produce the angle as much as possible.

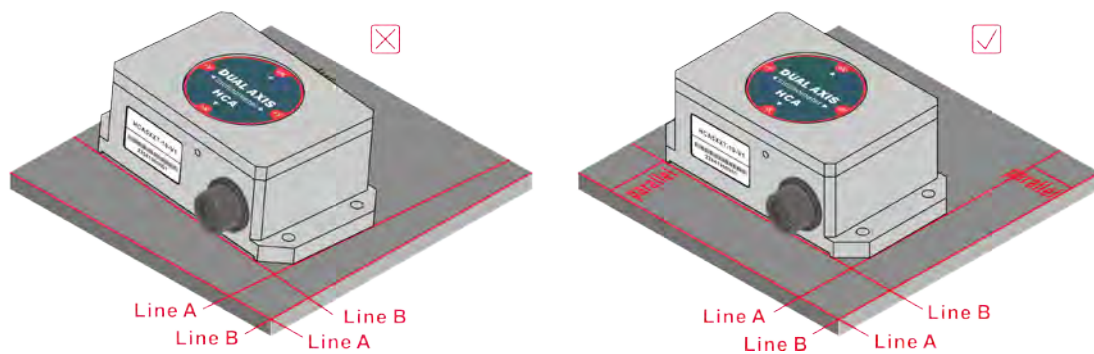

► MEASURING DIRECTIONS

SUCH

The installation must guarantee the product bottom is parallel to measured face, and reduce the influence of dynamic and acceleration to the sensor. This product can be installed horizontally or mounted vertically, for installation please refer to the following scheme.

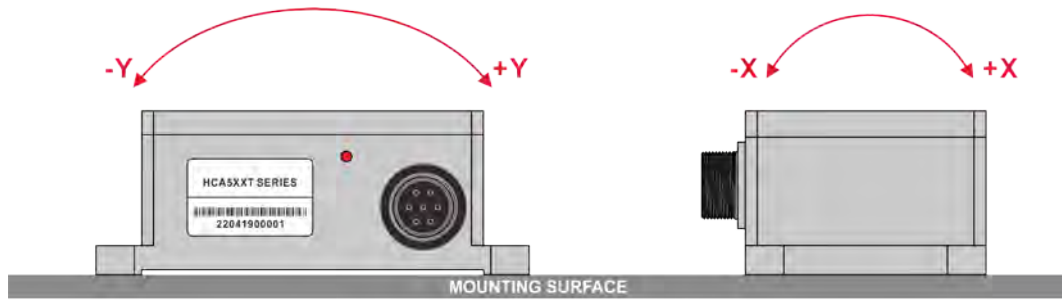

Horizontal installation

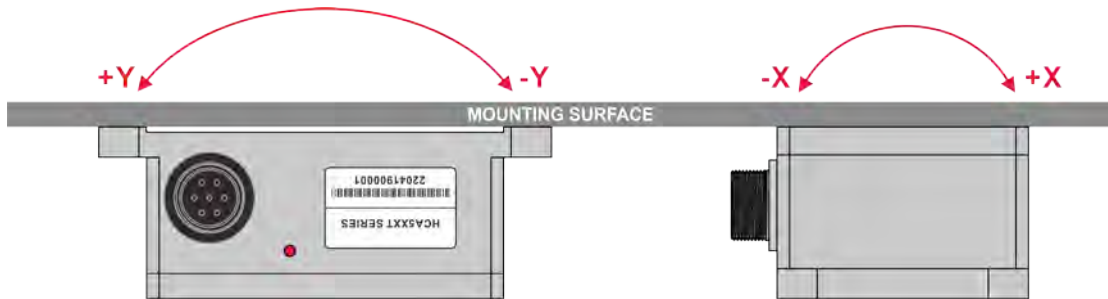

Horizontal-down installation

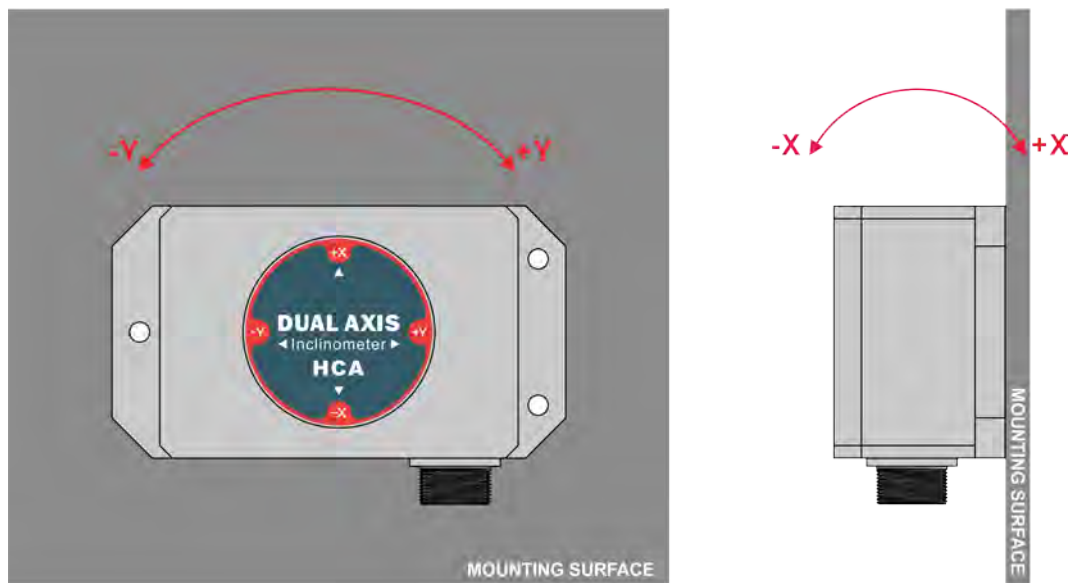

Vertical installation

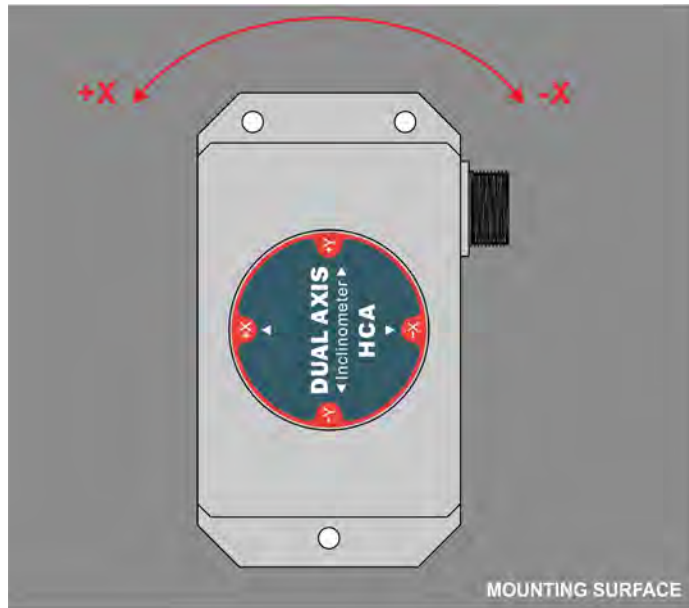

Vertical-left installation

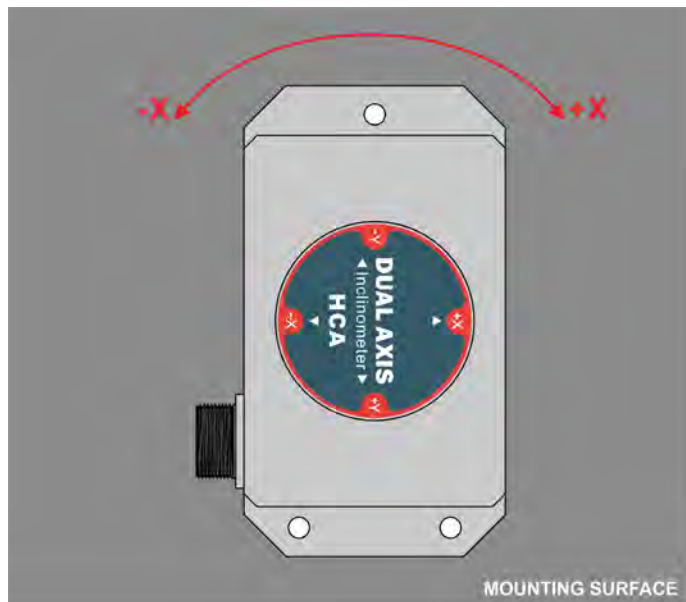

Vertical-right installation