

V2.8

FULL TEMPERATURE COMPENSATION INCLINOMETER
HCA716/HCA726

Technical Manual

○ Revision date: 2025-5-27

Note: Product functions, parameters, appearance, etc. will be adjusted as the technology upgrades, please contact our pre-sales business to confirm when purchasing.

Disclaimer

This product is developed exclusively for commercial applications and is prohibited from being used for illegal purposes, such as military activities, research related to nuclear, chemical, or biological weapons, or any other actions that violate laws and regulations. It is strictly forbidden to engage in activities related to goods embargoed by the United Nations, the European Union, or the OSCE, as well as any other activities prohibited by the Export Administration Regulations.

Without the written consent of our company, this product must not be transferred to any third party. Purchasing this product signifies your acceptance of this disclaimer and your agreement to sign the related liability agreement. If these regulations are violated, all responsibilities will be borne by the purchaser, and our company will not be held liable.



► GENERAL DESCRIPTION

HCA716S/HCA726S is a small volume full temperature compensated high-precision single / dual-axis inclinometer for industrial field control. It adopts RS485 / RS232 serial access interface. Built-in high-precision 24bit A / D differential converter, through the 5th order filtering algorithm, can measure the tilt and pitch angle of the sensor output relative to the horizontal plane. The product integrates the latest technology main MEMS tilting unit, the measure range up to $\pm 180^\circ$, and the full-scale accuracy is 0.01° , which can easily achieve dual-axis and single-axis tilt measurement. The product belongs to a real industrial grade product, with reliable and stable performance, good scalability, and multiple output options. It is suitable for the application of monitoring of ancient buildings, dilapidated buildings, ancient walls, etc., and large-scale high-precision measurement in industrial sites.

► FEATURES

- ★ Single / dual axis inclination measurement
- ★ Accuracy: Refer to data table
- ★ Wide temperature operation $-40 \sim +85^\circ\text{C}$
- ★ IP67 protection grade
- ★ Direct lead interface
- ★ Range $\pm 1 \sim \pm 180^\circ$ optional
- ★ DC 9 ~ 36V wide voltage input
- ★ Resolution 0.001°
- ★ High vibration resistance $> 100\text{g}$

► APPLICATION

- ★ Monitoring of ancient buildings and dilapidated buildings
- ★ Leveling of construction vehicles
- ★ Medical equipment angle control
- ★ Underground drilling rig attitude navigation
- ★ Elevation angle measurement of directional satellite communication antenna
- ★ Monitoring of bridges and large lands
- ★ Mining machinery, oil drilling equipment
- ★ Railway gauge ruler and gauge leveling
- ★ Geological equipment tilt monitoring

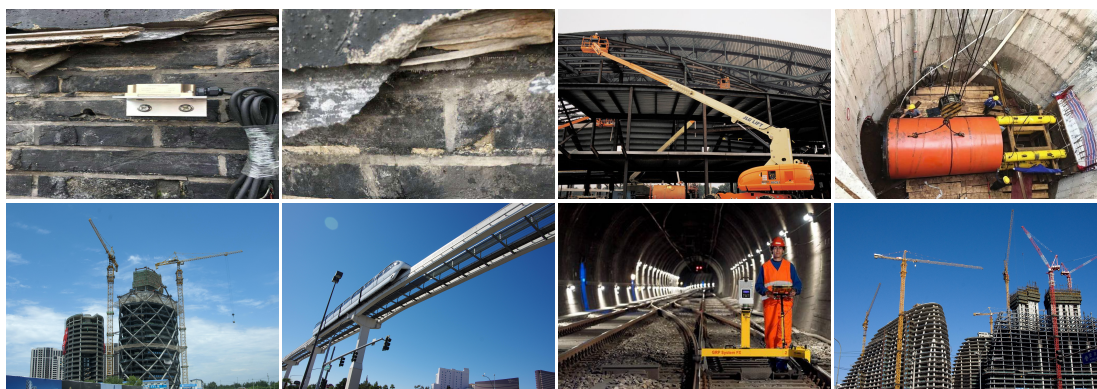

► SPECIFICATIONS

HCA716/HCA726		CONDITION	PARAMETERS					UNIT
Measure range			±10	±30	±60	±90	±180	°
Measure axis			X Y	X Y	X Y	X Y	X	axis
Resolution			0.001	0.001	0.001	0.001	0.001	°
Measure accuracy	MAXE	Room temp.	0.008	0.01	0.01	0.02	0.02	°
	RMSE	Room temp.	0.004	0.005	0.005	0.006	0.006	°
Zero Temp.coefficient		-40 ~ 85°C	±0.0005	±0.0005	±0.0005	±0.0005	±0.0005	%/°C
Sensitivity temp coeffi		-40 ~ 85°C	≤0.01	≤0.01	≤0.01	≤0.01	≤0.01	%/°C
Power on time			0.5	0.5	0.5	0.5	0.5	S
Response frequency			20Hz					
Interface			TTL / RS232 / RS485 optional					
Communication protocol			RION 68 protocol / MODBUS RTU protocol optional					
EMC			According to EN61000 and GBT17626					
MTBF			≥98000 hours/times					
Insulation Resistance			≥100MΩ					
Shockproof			100g@11ms / 3 Axial Direction (Half Sinusoid)					
Anti-vibration			10grms / 10 ~ 1000Hz					
Protection grade			IP67					
Cables			Standard configuration: 1m length, wear-resistant,oil-proof, wide temperature, shielded cable4*0.2mm2					
Weight			≤150g (including 1 meter cable)					

KEY WORDS

Resolution: Refers to the sensor in measuring range to detect and identify the smallest changed value.

MAXE: refers to the biggest error of the product within the range and at multiple angle points.

RMSE: refers to the root mean square difference between the measured value and the actual angle of the product within the range and for multiple times (more than 16 times).

Zero Temperature Drift Coefficient: the change rate of the indication value relative to normal temperature within the rated operating temperature range of the sensor at the zero degree.

Sensitivity Temperature Drift Coefficient: The percentage change rate with temperature of the full-scale indication relative to the full-scale indication at room temperature of the sensor in its rated operating temperature range.

► ELECTRONIC CHARACTERISTICS

PARAMETERS	CONDITIONS	MIN	STANDARD		MAX	UNIT
Power supply	Standard	9	12	24	36	V
Working current	No load		21	12		mA
Working temperature		-40			+85	°C
Store temperature		-40			+85	°C

► ORDERING INFORMATION

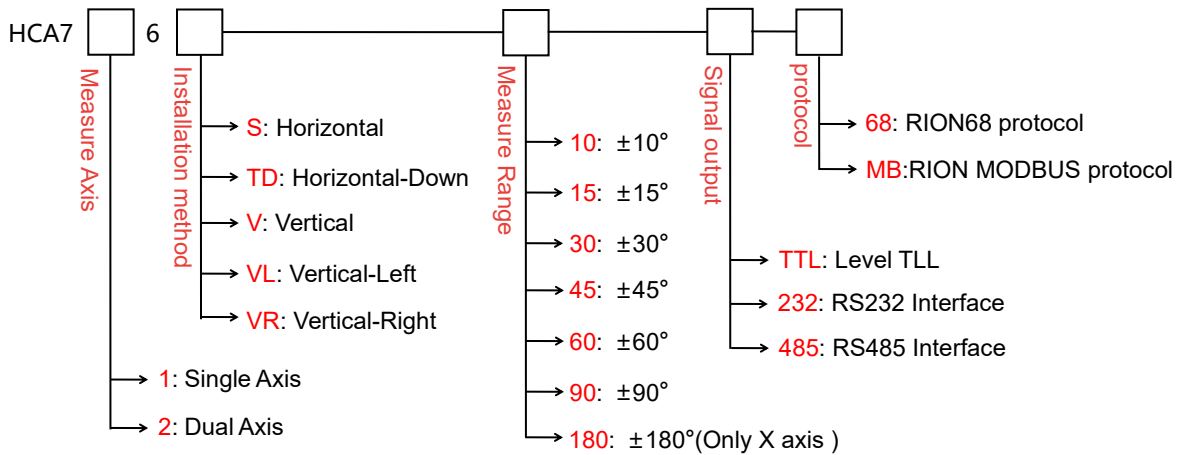

E.g : HCA716**S**-**10**-**232**-**68** : Single axis / standard horizontal / ±10° measure range / RS232 signal output / RION68 protocol.

Note:Vertical measurement installation only for single axis X axis.

► MECHANICAL PARAMETERS

- Connector: 1m Direct Leading Cable (Can Be Customized)
- Protection level: IP67
- Shell material: aluminum alloy shield oxidation
- Installation: Four M4 screws

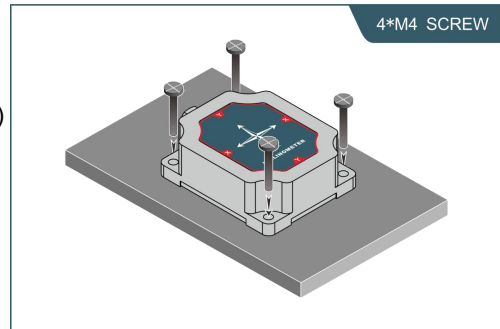

► WORKING PRINCIPLE

Adopt imported core control unit and apply the principle of capacitive micro-pendulum. Using the principle of earth's gravity, when the tilting unit tilts, the earth's gravity will produce a gravitational component on the corresponding pendulum, and the corresponding electric capacity will change. By amplifying and filtering the electric capacity, the inclination is obtained after conversion.

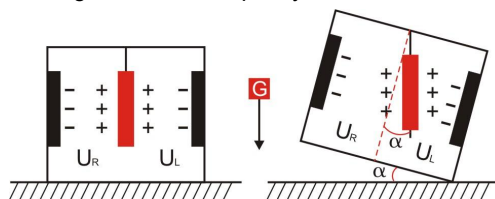

U_R, U_L respectively is the pendulum left plate and the right plate corresponding to their respective voltage between the electrodes, when the tilt sensor is tilted, U_R, U_L will change according to certain rules, so $f(U_R, U_L)$ On the inclination of α function:

$$\alpha = f(U_R, U_L)$$

► ELECTRICAL CONNECTION

FUNCTION COLOR	BLACK	WHITE	GREEN	RED
	GND Power negative	RS485(D+) RS232(RXD) TTL(RXD)	RS485(D-) RS232(TXD) TTL(TXD)	DC9~36V Power supply positive

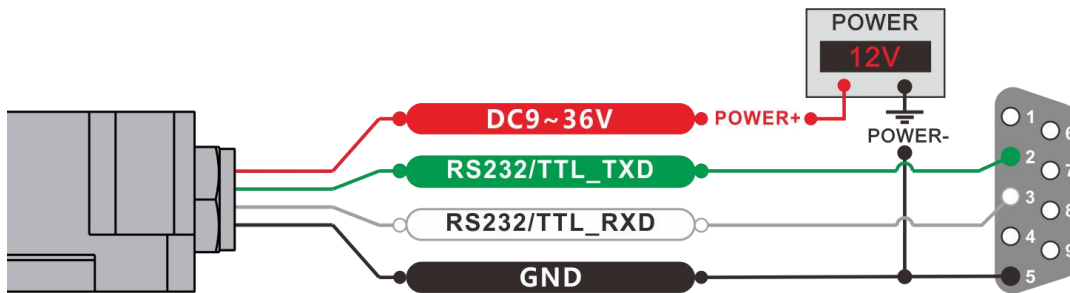
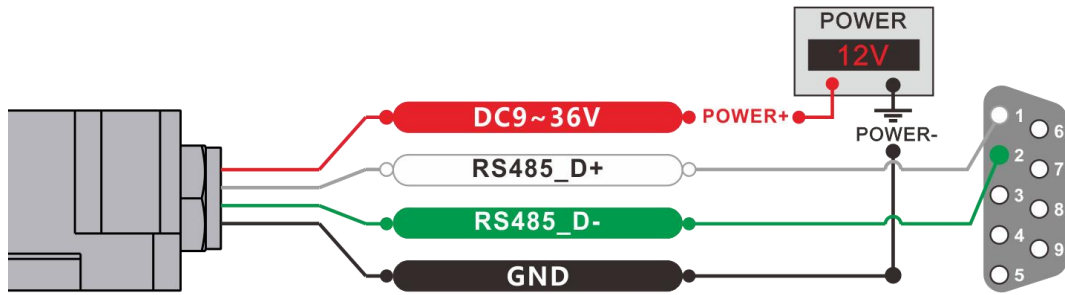

► DIMENSION

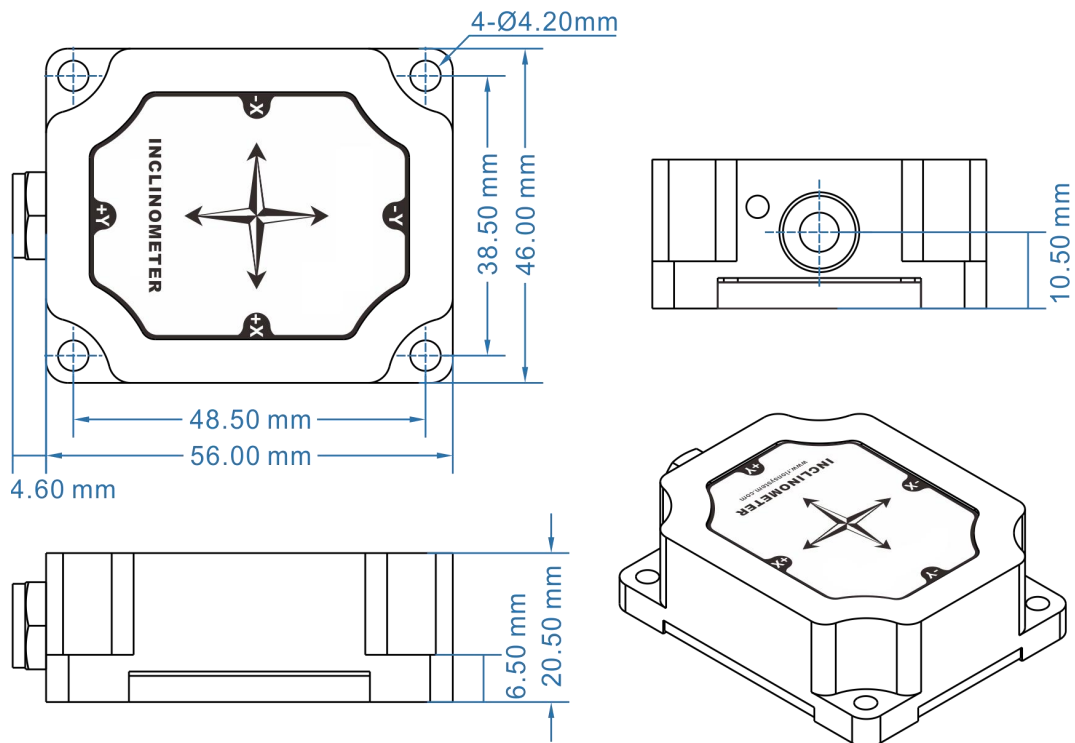

Shell size: L56×W46×H20.5mm

Installation size: L48.5×W38.5×H6.5mm

Mounting screws: 4 M4 screws

► PRODUCTION INSTALLATION NOTES

Please follow the correct way to install tilt sensor, incorrect installation can cause measurement errors, with particular attention to the "surface", "line"::

- 1) The Sensor mounting surface and the measured surface must be fixed closely, smoothly, stability, if mounting surface uneven likely to cause the sensor to measure the angle error.
- 2) The sensor axis and the measured axis must be parallel, the two axes do not produce the angle as much as possible.

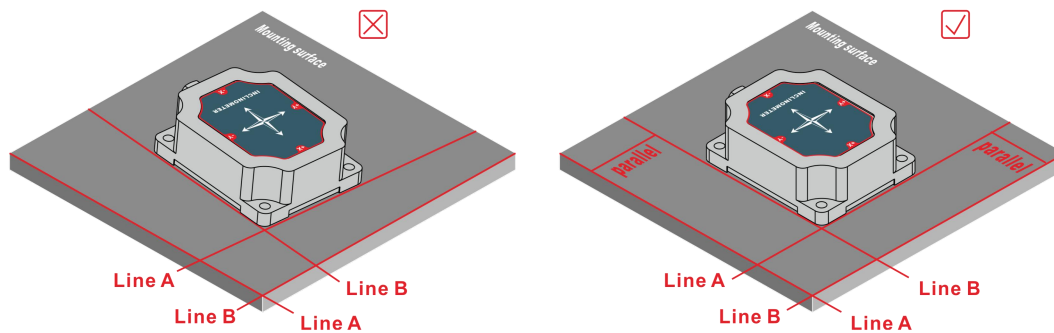

► MEASURING DIRECTIONS

The installation must guarantee the product bottom is parallel to measured face, and reduce the influence of dynamic and acceleration to the sensor. This product can be installed horizontally or mounted vertically (vertical installation selection is only applicable to single axis), for installation please refer to the following scheme.

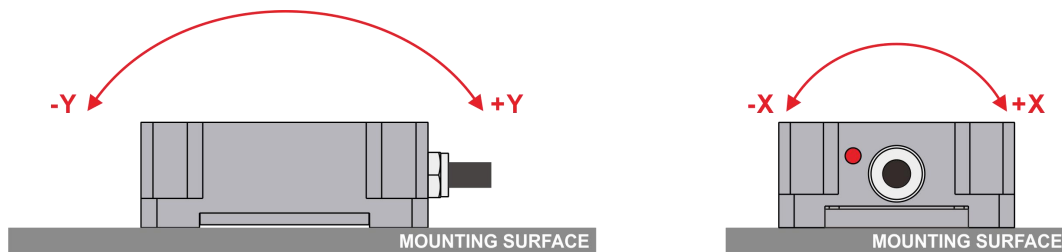

Horizontal installation

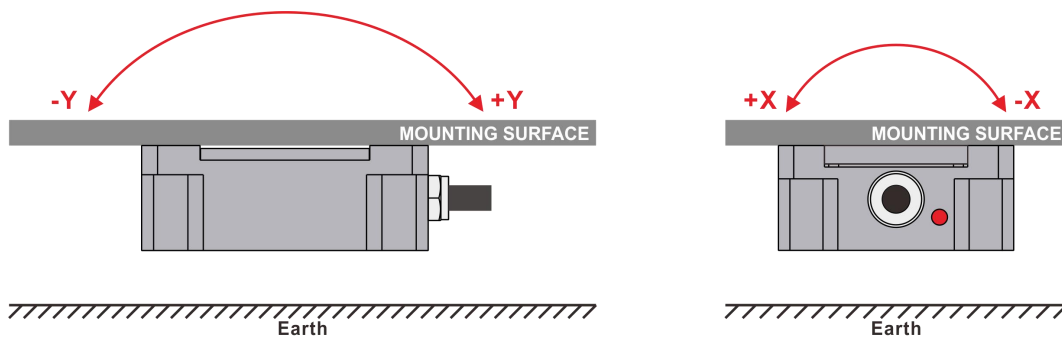

Horizontal-down installation

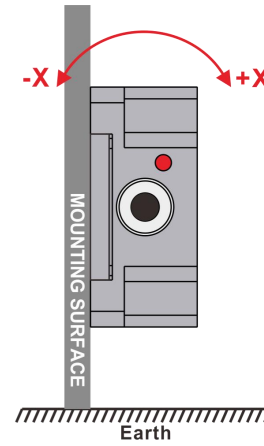
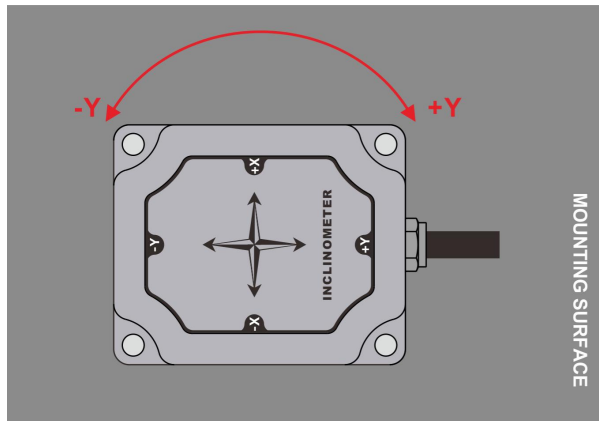

Vertical-left installation

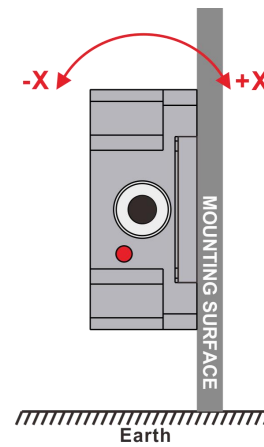
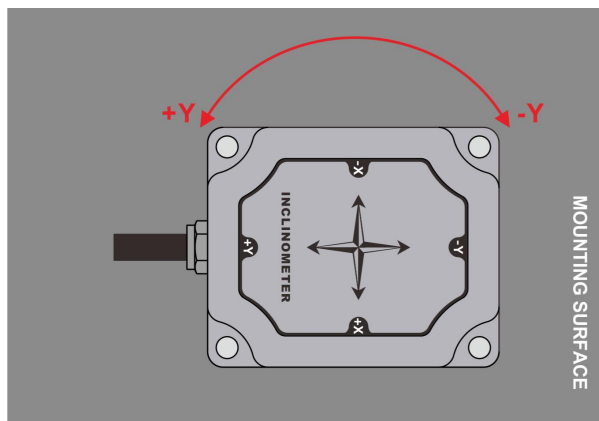

Vertical-right installation

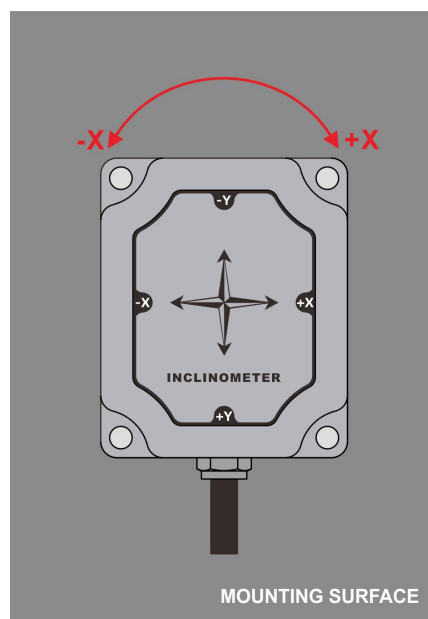

Vertical installation

► 68 COMMUNICATION PROTOCOL

1. Data frame format : (8 data bits, 1 stop bit, No check, default rate is 9600)

Identifier (1byte)	Date Length (1byte)	Address code (1byte)	Command Word (1byte)	Date domain	Check sum (1byte)
68					

Data format: hexadecimal .

Identifier:Fixed68.

Data length:From data length to check sum(including check sum)length.

Address code:Accumulating module address,Default :00.

Date domain will be changed according to the content and length of command word.

Check sum:Data length/Address code/Command word and data domain sum,No carry.

2. COMMAND word analysis

Attention to parameter setting: All settings required by the 68 command should be saved by sending the command 6804005357 to save the parameters.

Command word	Meaning/Example	Description
0X04	Read X and Y angle commands simultaneously E.g: 68 04 00 04 08	Data domain(0byte) No Data domain command
0X84	Sensor response /answer E.g: 68 0F 00 84 00 20 10 00 10 05 25 00 00 50 50 9D	Data domain(9byte) SA AA BB CC SD DD EE FF SG GG HH SA AA BB CC: 4 characters represent the X axis. 00 20 10 00 The four red bytes return the angle value for the X axis,is compact BCD code,High byte of the first byte 0 is Sign bit(0 positive,1 negative) 020 is a three-digit integer value, 10 00 is four Decimal value. Other axis data is the same. This angle analyze +20.100deg. 10 05 25 00 : Four characters represent Y axis. 00 50 50 :The internal temperature value of the three-character,analyze in the same way as the X-axis angle. Angle format is the same as X axis or Y axis for analyze. The angle in the left example is: X axis 20.10deg, Y axis -5.25deg, Temperature:+50.5°C
0X05	Setting relative/absolute zero: Can set the current angle to Zero degree for relative measurement,can also be set to absolute ex-factory zero,power off save. E.g: 68 05 00 05 00 0A	Data domain(1byte) 00 Absolute ZERO 01 Relative ZERO
0X85	Sensor response /answer command E.g: 68 05 00 85 00 8A	Data domain (1byte) The number in the data domain indicates the result of the sensor response 00 Success FF Failure

0X0B	<p>Setting communication rate E.g:68 05 00 0B 03 13 Note: It will take effect immediately after setting (but not saved to FLASH)</p>	<p>Data domain(1byte) Baud rate:Factory default 9600 00 means 2400 01 means 4800 02 means 9600 03 means 19200 04 means 38400 05 means 115200</p>
0X8B	<p>Sensor response /answer command E.g: 68 05 00 8B 00 90</p>	<p>Data domain (1byte) The number in the data domain indicates the result of the sensor response 00 means Success FF means Failure</p>
0X0C	<p>Setting sensor output mode Response rule:Need upper computer send reading angle command , the sensor answer the corresponding angle . Automatic output Mode: The sensor automatically outputs X and Y angles when powered on, with the output frequency specified in the table on the right. (Power-off memory is supported.) E.g:68 05 00 0C 00 11</p>	<p>Data domain(1byte) 00:Answer reply mode(Factory default) 01:5Hz Auto output mode 02:15Hz Auto output mode 03:25Hz Auto output mode 04:35Hz Auto output mode 05:50Hz Auto output mode Note: When the setting value is greater than 128, the output frequency is calculated as XX minus 128; for example, 81H corresponds to 1 Hz. When using the RS485 bus, automatic output is only supported when a single device is connected.</p>
0X8C	<p>Sensor response /answer command E.g:68 05 00 8C 00 91</p>	<p>Data domain (1byte) The number in the data domain indicates the result of the sensor response 00 Success FF Failure</p>
0X0F	<p>Setting module address command The sensor default address is 00. 1.such as a plurality of sensor to be connected with a bus cable, e.g RS485.requires each sensor is set to a different address, in order to achieve control and response angle . 2.If successfully changed the new address, follow all of the commands and responding Packet address code has to switch to the new address code which already changed then to be effective, otherwise the sensor will not respond to commands. E.g:68 05 00 0F 01 15 Setting the address to 01. 68 05 FF 0F 00 13 Use the common address to reset address to 00.</p>	<p>Data domain(1byte) XX Module address Address from 00 to EF range Note: All products have a common address:FF, If forget the address what has been set during operation , can use FF address to operate the product can still normally respond. Note: It will take effect immediately after setting (but not saved to FLASH)</p>
0X8F	<p>Sensor response /answer command E.g:68 05 00 8F 00 94</p>	<p>Data domain (1byte) The number in the data domain indicates the result of the sensor response 00 Success FF Failure</p>

0X0D	Query relative/absolute ZERO Used to query the sensor current ZERO mode is relative ZERO or absolute ZERO E.g:68 04 00 0D 11	Data domain(0byte) No Data domain command
0X8D	Sensor response /answer command E.g:68 05 00 8D 00 92	Data domain (1byte) The number in the data domain indicates the result of the sensor response 00 Absolute ZERO 01 Relative ZERO
0X53	Set save command E.g:68 04 00 53 57	Data domain(0byte) No Data domain command
0X53	Sensor response /answer command E.g:68 05 00 D3 00 D8	Data domain(1byte) The number in the data domain indicates the result of the sensor response 00 Success FF Failure
0X1F	Read software version number	No data domain
0X9F	Sensor response reply command E.g:68 14 00 9F 52 43 41 38 32 36 54 5F 56 32 31 30 34 30 38 41 A2	Data domain(16byte) The data field is in string format As version number: HCA726T_V210408A

▶ PRODUCT MODBUS COMMUNICATION PROTOCOL

Attention, please read the following items carefully before use:

1. Due to the MODBUS protocol's requirement that the time between two data frames should be at least 3.5 bytes (e.g. at 9600 baud rate, this time is $3.5 \times (1/9600) \times 11 = 0.004s$). But in order to leave enough margin, this sensor has increased this time to 10ms, so please leave at least 10ms of time interval between each data frame.
Host sends command -10ms idle - Slave replies command -10ms idle - Host sends command
2. The MODBUS protocol specifies the relevant content of broadcast address -0, and this sensor can also accept broadcast address content, but will not respond to it. So the broadcast address 0 can be used for the following purposes, for reference only.
 - 1) Set all the addresses of the tilt sensors of this model mounted on the bus to a certain address.
 - 2) Set all tilt sensors of this model mounted on the bus to relative/absolute zero.
 - 3) Test the sensor of this model on the entire bus, that is, if the host sends a 0 address inquiry angle command to the bus and the communication indicator light flashes, the communication is normal.
 3. In order to improve the reliability of the system, the address command and absolute/relative command, as well as the baud rate, must be sent twice in a row to be effective. 'Sending twice in a row' refers to sending successfully twice (with a response from the slave each time), and the two question and answer sessions must be consecutive, meaning that the host cannot insert other data frames in between. Otherwise, this command will be locked until power is lost. The setup process is as follows:
Send Set Address Command - Wait for Successful Setting Command from Slave - (No other commands allowed) Send Set Address Command Again - Wait for Successful Setting Command from Slave - Modify Successful
4. After power on, the address command, baud rate, and communication character format can only be set once. If you need to set them again, you need to power on again.
5. When normal communication accumulates to a certain number of times, the communication indicator light will flash once.

1. One Data frame format

RTU mode.

Communication parameters: baud rate 9600 bps.

Data frame: 1 start bit, 8-bit data, even parity check, 1 stop bit.

2. Read angle data

Modbus function code 03H, application example of read data command:

Host query command:		Slave response:		
Sensor address	01H	Sensor address	01H	
function code	03H	function code	03H	
Accessing the first address of the register	00H	Data field length	08H	
	02H	Data domain	5AH	
Number of registers	00H		60H	X-axis data
	04H		01H	
CRC	E5C9H		00H	
			47H	Y-axis data
			62H	
			01H	
			00H	
		CRC	C5B9H	

Note: The data fields of the slave reply frame are 5AH, 60H, 01H, 00H, 47H, 62H, 01H, 00H
 The X-axis represents the first to fourth bytes of the data field, the Y-axis represents the fifth to eighth bytes of the data field, and the lower bytes come first. The representation method of angle is point based representation, where one point corresponds to 0.001 ° and 0.001 × (point offset) is the angle. If the measurement range is ±180 °, the total number of points is 360000. So 0 corresponds to -180 °, 360000 corresponds to +180 °, and 180000 corresponds to 0 °.

Taking the above data frame as an example, the process of angle conversion is as follows:

1) Obtain the current angle point count, note that the low byte comes first, the X-axis is 0001605AH, and the Y-axis is 00016247H.

2) Convert to decimal, X-axis: 0001605AH → 90202, Y-axis: 00016247H → 90695.

3) Subtract the offset of 180000 (note: this value is a quantity related to the measurement range),

X-axis: 90202-180000=-89798, Y-axis: 90695-180000=-89305.

4) Obtain the final angle, X-axis: -89798 × 0.001=-89.798 °, Y-axis: -89305 × 0.001=-89.305 °.

3. Set the relative/absolute zero point of the sensor: (MODBUS function code 06H)

Set relative/absolute zero command:		Slave response:	
Sensor address	01H	Sensor address	01H
function code	06H	function code	06H
Accessing the first address of the register	00H	Register address	00H
	10H		10H
If the character is non-zero, it is a relative zero point, and if it is zero, it is an absolute zero point	00 H	If the character is non-zero, it is a relative zero point, and if it is zero, it is an absolute zero point	00H
	FFH / 00H Relative/Absolute		FFH / 00H Relative/Absolute
CRC	C84FH/ 880FH	CRC	C84FH/ 880FH

Example of setting relative/absolute zero command application:

Host sends	01H	06H	00H	10H	00H	FFH	C8H	4FH
Reply from the machine	01H	06H	00H	10H	00H	FFH	C8H	4FH

Note: 0010 is the register address, which controls whether the sensor output is relative zero or absolute zero. If it is non-zero (as in the above example, 00FFH is written), then the output is relative zero. On the contrary, if it is zero (by changing the 5th and 6th bytes to 00H), it is an absolute zero. The last two bytes are the CRC checksum.

4. Set sensor address:

Set sensor address code command:		Slave response:	
Sensor address	01H	Sensor address	01H
function code	06H	function code	06H
address	00H	Register address	00H
	11H		11H
New address for sensor	00 H	New address for sensor	00 H
	04H		04H
CRC	D80C	CRC	D80C

The command must be sent twice in a row to be effective

Example application of setting sensor address command:

Host sends	01 H	06 H	00 H	11 H	00 H	04H	D8H	0CH
Reply from the machine	01 H	06 H	00 H	11 H	00 H	04H	D8 H	0CH

Note: 0011H is the register address, which controls the sensor address. In the above example, the address of the sensor is changed to 0004H, and the last two bytes are the CRC checksum.

5. Set sensor baud rate: (Factory default is 9600bps)

Set sensor baud rate:		Slave response:	
Sensor address	01H	Sensor address	01H
function code	06H	function code	06H
address	00H	Register address	00H
	12H		12H
The baud rate of the sensor	00H	The baud rate of the sensor	00H
	XX		XX
CRC	CRC LH	CRC	CRC LH

XX : A0H:4800 A1H:9600 A2H:19200 A3H:38400 A4H:115200

The command must be sent twice in a row to be effective

Example application of setting sensor baud rate command:

Host sends	01 H	06 H	00 H	12 H	00 H	A2H	A8H	76H
Reply from the machine	01 H	06 H	00 H	12 H	00 H	A2H	A8 H	76H

Note: 0012H is the register address, which controls the sensor baud rate. In the above example, the baud rate of the sensor is set to 19200, and the last two bytes are the CRC checksum.

6. Set sensor communication character format:

Set sensor communication character format:		Slave response:	
Sensor address	01H	Sensor address	01H
function code	06H	function code	06H
address	00H	Register address	00H
	09H		09H
Sensor changes communication character format	00 H	New format for sensors	00H
	01H		01H
CRC	9808	CRC	9808

Example of setting sensor communication character format application:

Host sends	01 H	06 H	00 H	09 H	00 H	01H	98H	08H
Reply from the machine	01 H	06 H	00 H	09 H	00 H	01H	98 H	08H

The above example is to set the byte format to: one start bit+8 data bits without parity+1 stop bit.

Effective after powering on again. The factory default is a start bit+8 data bit parity+1 stop bit.

Note: 0009 is the register address, which controls the communication character format of the sensor.

0000H: One start bit+8 data bit parity checks+1 stop bit.

0001 H: One start bit+8 data bits without checksum+1 stop bit.

7. Set sensor output mode: (factory default 0HZ)

Set sensor output mode command:		Slave response:	
Sensor address	01H	Sensor address	01H

function code	06H	function code	06H
address	00H	Register address	00H
	13H		13H
Output mode of sensor	00H	Output mode of sensor	00H
	XX		XX
CRC	CRC LH	CRC	CRC LH

XX:00H:Q&A mode 01H:10Hz 02H:25Hz
03H:50Hz 04H:5Hz 05H:15Hz 06H:100Hz

When the set value is greater than 128, the output frequency is XX-128; If 81H is 1Hz.