

# SUCH

## High Precision Tilt Sensor User Manual



**(Product Specification)**

**Model: AVT2000T**

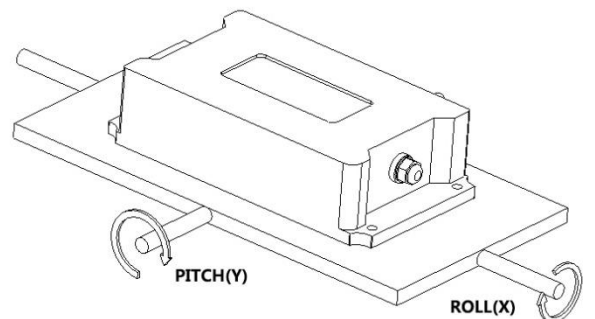

## 1. Product Features

The AVT2000T is a full temperature-compensated, ultra-high-precision dual-axis inclination sensor launched by SUCH, with a resolution of  $0.0005^\circ$ , accuracy of  $0.001^\circ$ , and temperature drift of  $0.0005^\circ/\text{C}$ . Output interfaces include RS232, RS485, RS422, TTL, and CAN bus options.

The product transmits digital signals and is equipped with professional computer software for data measurement and recording. Its non-contact installation feature provides excellent system integration and convenient installation. Simply fix the sensor to the surface of the object to be measured with screws to calculate the horizontal angle of the object. It is easy to use. It has strong resistance to external electromagnetic interference and shock and vibration, making it an ideal choice among similar products in China.

## 2. Product Performance

- Dual-axis tilt monitoring
- Output frequency: 5 to 100 Hz
- Output options: RS232/RS485/TTL/RS422/CAN
- Wide voltage input: DC 11 to 36 V
- Dimensions: 107 x 55 x 27 mm
- High vibration resistance >20000g
- Range  $\pm 0$  to  $\pm 5/\pm 15/\pm 30$  (optional)
- Baud rate 2400 to 115200
- Wide temperature range:  $-40$  to  $+85^\circ\text{C}$
- IP67 protection rating

## 3. Product Application

- Railway locomotive monitoring
- Vehicle chassis monitoring
- Precision machine tool level control
- Gimbal leveling
- Ship navigation attitude measurement
- Precision laser platform equipment
- Based on tilt monitoring
- Satellite solar antenna positioning
- Medical equipment
- Various types of construction machinery angle control



## Product Performance Indicators

Specs	Condition	AVT2000T-5	AVT2000T-10	AVT2000T-15	AVT2000T-30	Unit
Range		±5	±10	±15	±30	°
Axis		X, Y axis	X, Y axis	X, Y axis	X, Y axis	
0°C Temp Drift	-40 ~ 85°	±0.0005	±0.0005	±0.0005	±0.0005	°/°C
Sensitivity Temp Coefficient	-40 ~ 85°	≤50	≤50	≤50	≤50	ppm /°C
Frequency Response	DC response	100	100	100	100	Hz
Resolution		0.0005	0.0005	0.0005	0.0005	°
Accuracy	-40 ~ 85°C	0.001	0.002	0.003	0.005	°
Term stability	-40 ~ 85°C	<0.002	<0.003	<0.004	<0.006	°
Power-up time		0.2	0.2	0.2	0.2	s
Response time		0.01	0.01	0.01	0.01	s
Rate	5Hz output, 15Hz, 35Hz, 50Hz can be set (RS485 No such function)					
Output Signal	RS232/RS485/RS422/TTL/PWM/CAN					
Avg. working time	≥45000 hour/sec					
Anti-impact	20000g,0.5ms,3 times/axis					
Anti-vibratio	10grms, 10 ~ 1000Hz					
Insulation resistance	≥100MΩ					
Waterproof Level	IP67					
Cable Wire	Standard: 1.5-m, wear-resistant, oil-resistant, wide temp range, shielded cable wire 5*0.2mm2					
Weight	250g (excluding packaging box)					

\* These performance parameters only list the ±5°, ±10°, ±15°, and ±30° series for reference. For other measurement ranges, please refer to the closest adjacent parameters.

## Electrical Specifications

Spec	Condition	Minimum	Typical	Maximum	Unit
Supply Voltage		11	12	36	V
Working Current	No load		40		mA
Working Temp		-40		+85	°C
Storage Temp		-55		+125	°C

## Definition of terms:

**Resolution:** Refers to the smallest change in the measured value that the sensor can detect and distinguish within its measurement range.

**Accuracy:** Absolute accuracy refers to the combined error of the sensor's absolute linearity, repeatability, hysteresis, zero-point deviation, and cross-axis error under normal temperature conditions.

**Long-term stability:** Long-term stability refers to the deviation between the maximum and minimum values of the sensor after one year of continuous operation under normal

temperature conditions. **Response time:** Response time is the time required for the sensor output to reach the standard value during a single angular change.

## Mechanical Properties

Connector	Lead wire (1.5 m)
Protection Level	IP67
Shell Material	Aluminum alloy sandblasted oxidation
Installation	3*M4 screws

## Working Principle

Utilizing a high-quality core control unit based on the capacitive micro-pendulum principle. Leveraging the principle of Earth's gravity, when the inclination unit tilts, Earth's gravity generates a gravitational component on the corresponding pendulum, causing the capacitance to change. By amplifying, filtering, and converting the capacitance measurements, the inclination angle is determined.

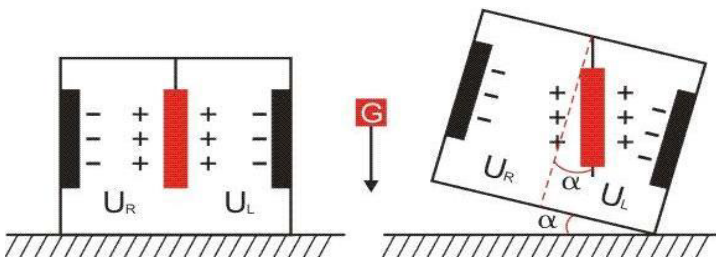

$U_R$  and  $U_L$  are the voltages between the left and right plates of the pendulum and their respective electrodes. When the tilt sensor tilts,  $U_R$  and  $U_L$  change according to a certain pattern, so  $f(U_R, U_L)$  is a function of the tilt angle  $\alpha$ :  $\alpha = f(U_R, U_L)$

## Product measurement direction & installation method

When installing, ensure that the sensor mounting surface is parallel to the surface of the target being measured. This product can be installed horizontally or vertically. For installation methods, please refer to the diagram below (single-axis X, Y optional):

**Figure 1: Horizontal upward and downward installation**

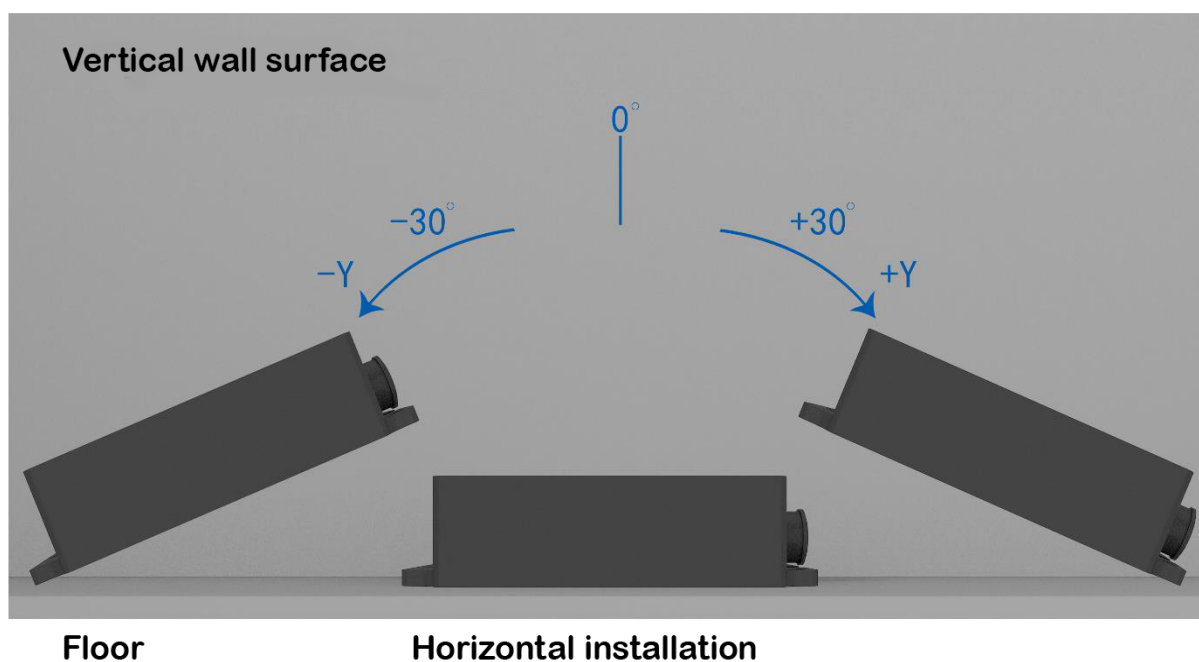
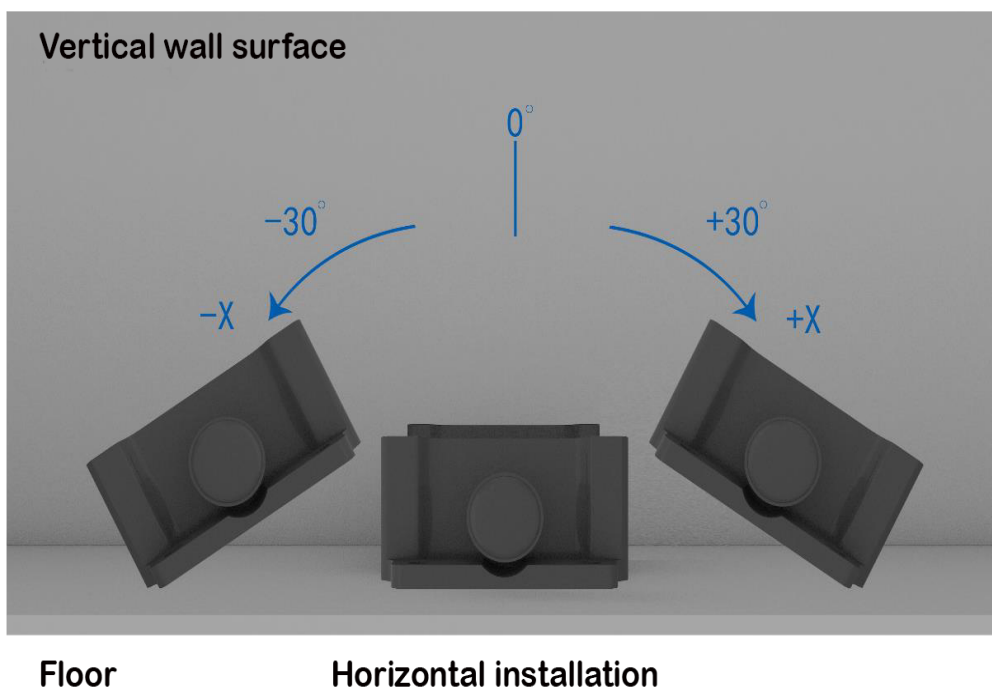
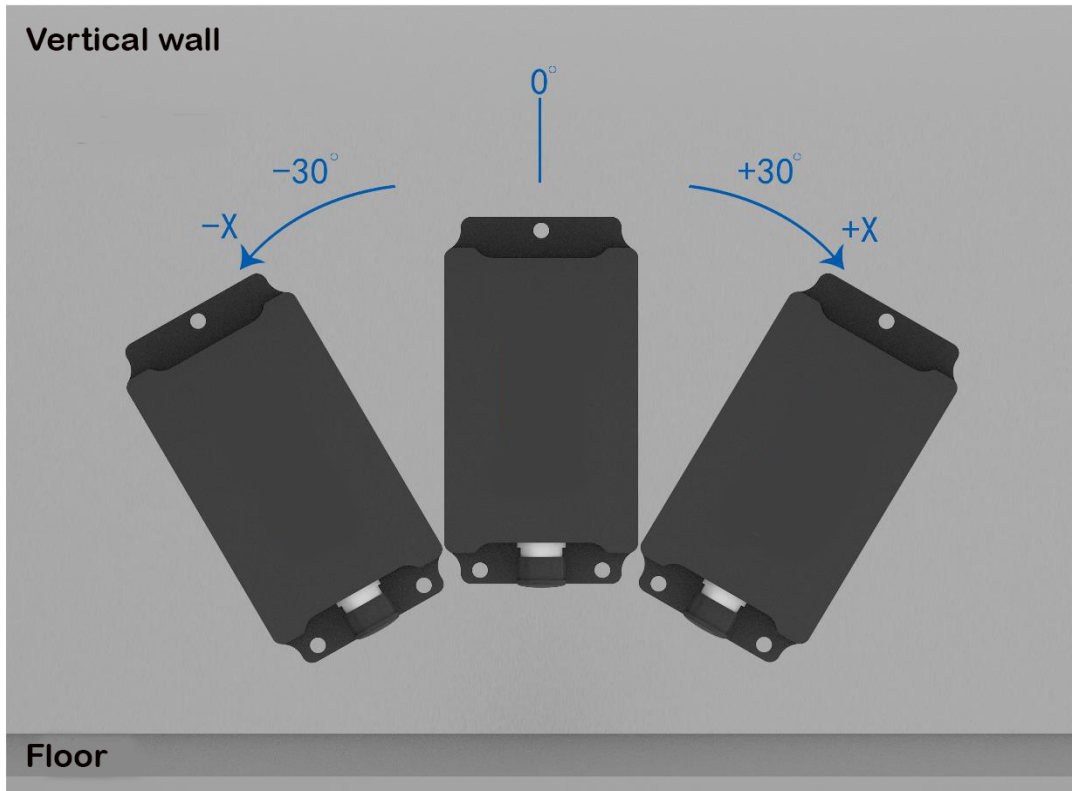
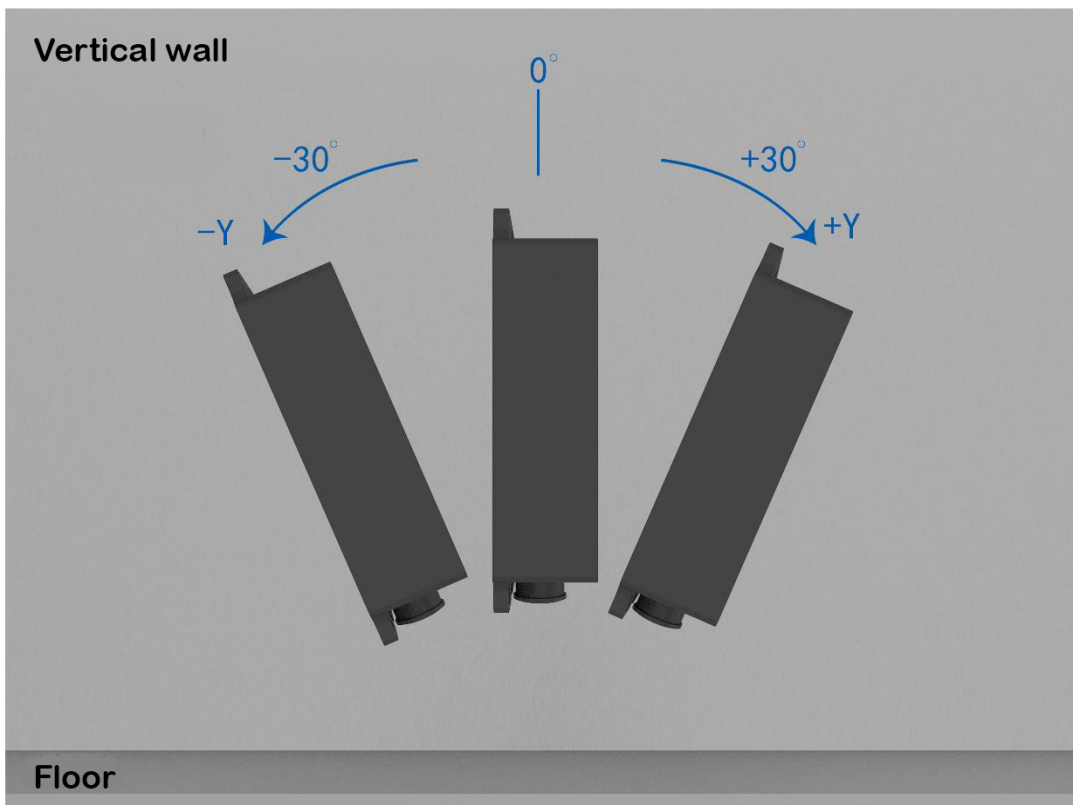

Figure 2: Vertical upward and downward installation



Vertical downward installation



Vertical downward installation

Figure 3: Vertical leftward and rightward installation (customization required)

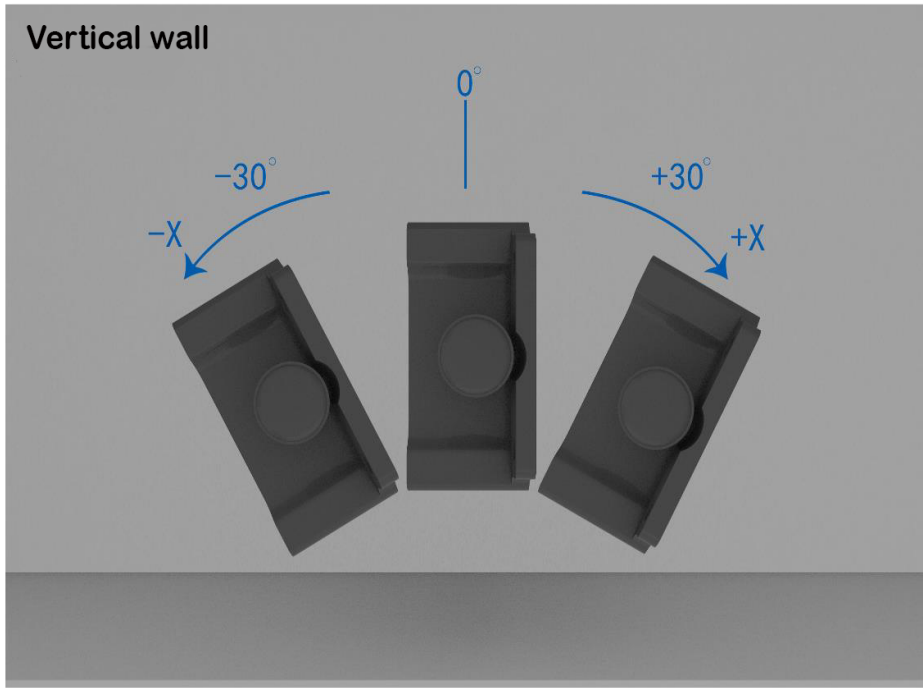

Floor

Vertical left installation

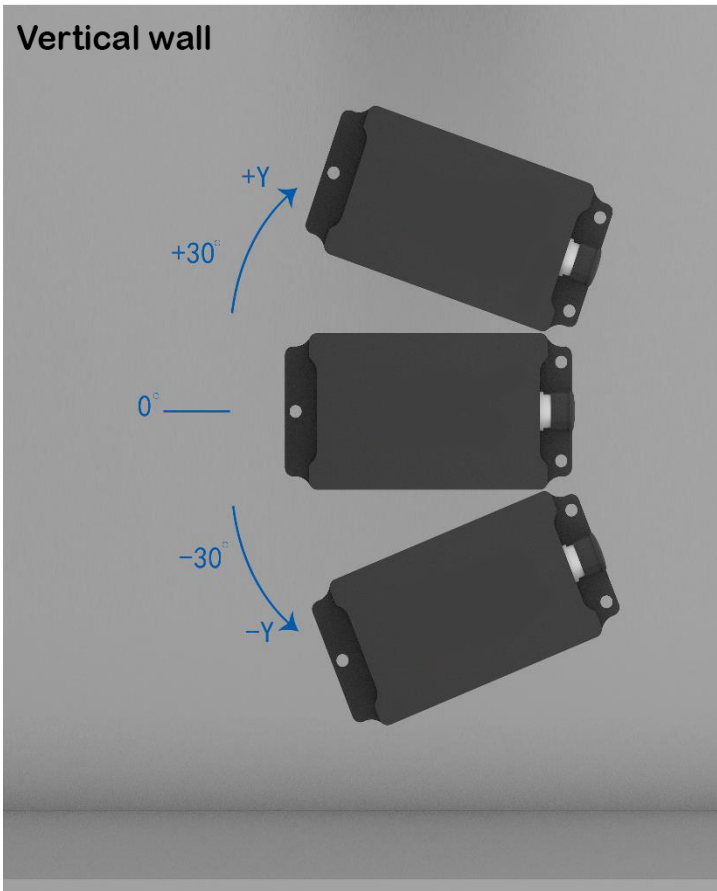

Floor

Vertical rightward installation

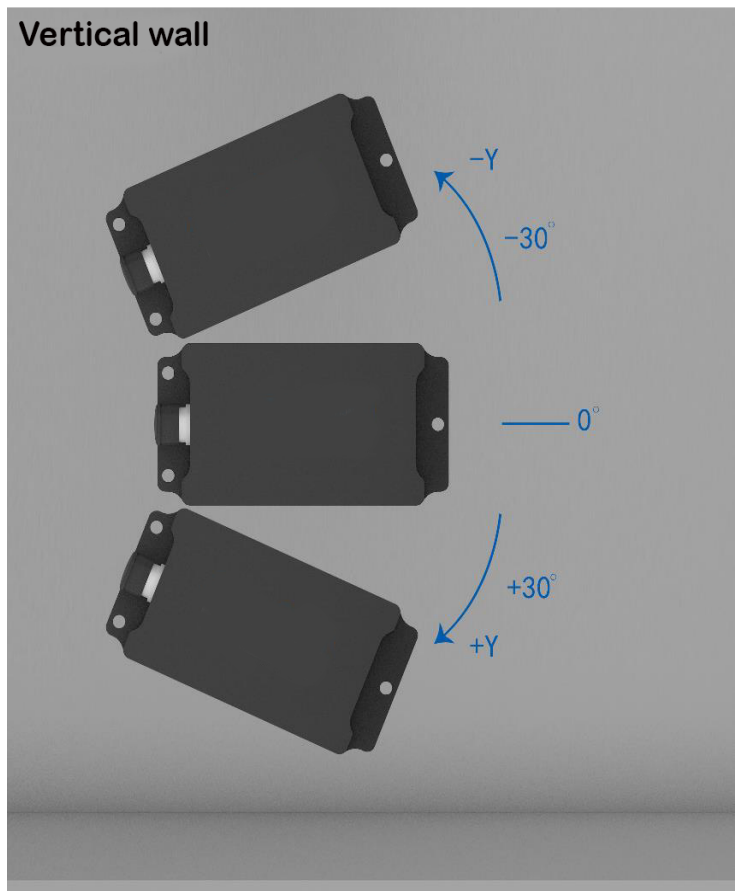

Floor

Vertical left installation

## Product Installation Precautions

Please install the inclination sensor correctly. Incorrect installation may result in measurement errors. Pay special attention to the "surface" and "lines": 1) The installation surface of the sensor must be securely fixed to the measured surface, ensuring it is flat, stable, and free of unevenness. Any unevenness in the installation surface may cause measurement errors in the sensor's angle measurement. See Figures A and B. 2) The sensor axis must be parallel to the measured axis, and the two axes should not form an angle whenever possible. See Figures C and D.

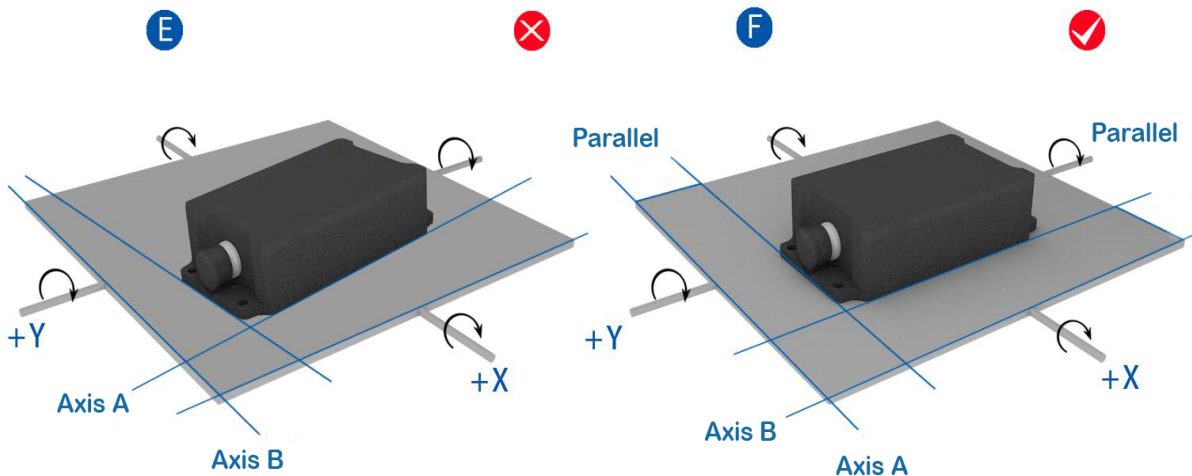
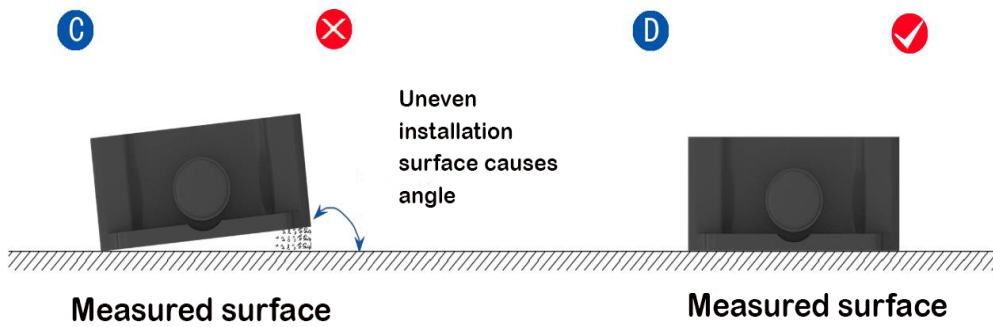
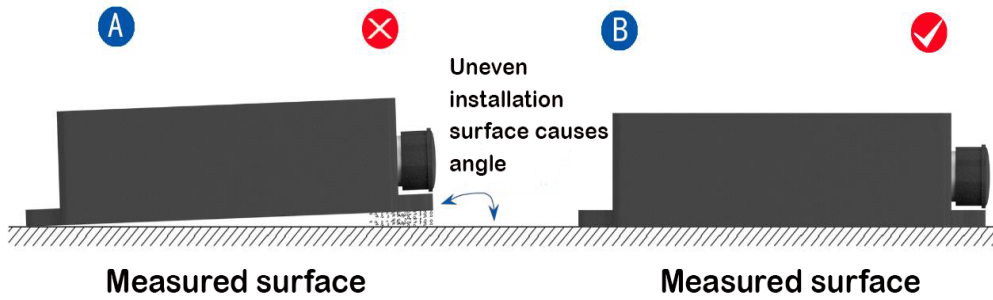

## Product dimension drawing

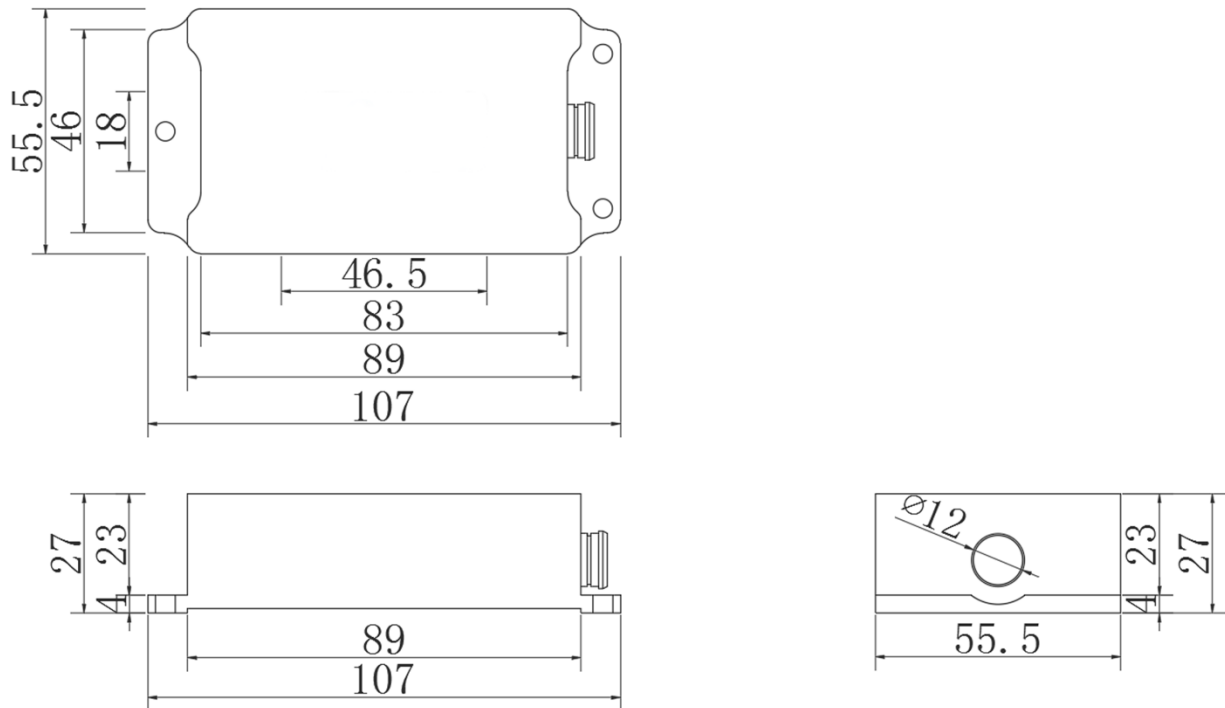

Product dimensions: L107\*W55\*H27MM

Default horizontal upward installation: When installing, ensure that the sensor mounting surface is parallel to the surface of the target being measured. Refer to the rotation diagram for the installation method. For other installation methods, refer to the "Product Installation Methods" diagram and make a note of this when ordering.

## Product electrical connection

Function	RED	WHITE	BLACK	GREEN	YELLOW
Interface	1	2	3	4	5
RS232	VCC	NC	GND	RXD	TXD
RS485	VCC	NC	GND	(B, D-)	(A, D+)
TTL	VCC	NC	GND	RXD	TXD

## Product electrical connection

Function	RED	BLACK	GREEN	YELLOW	WHITE	BROWN
Interface	1	2	3	4	5	6
RS422	VCC	GND	RXD- (B-)	RXD+ (A+)	TXD+ (A+)	TXD- (B-)

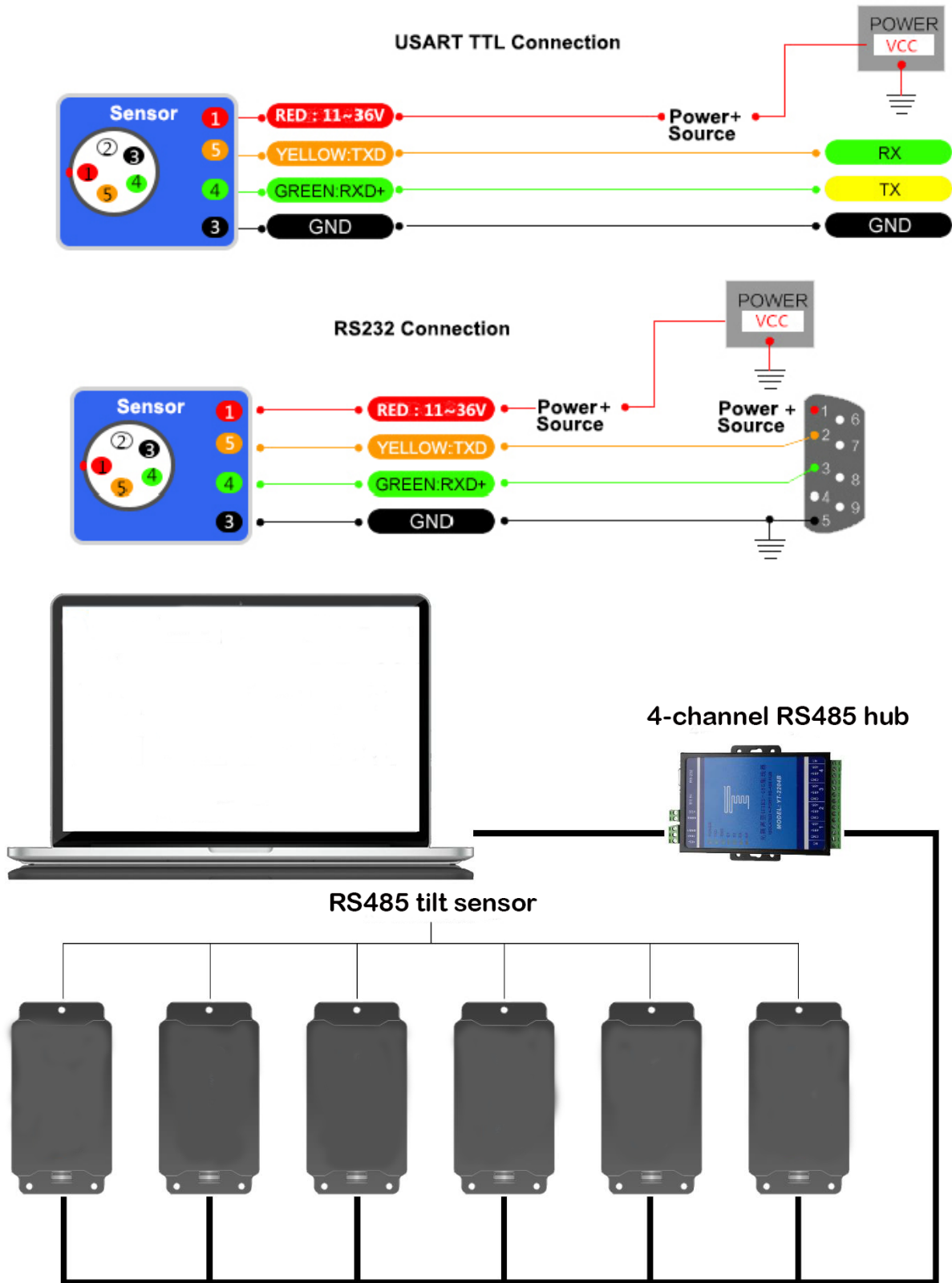

## Debugging software

Please contact our technical staff to download the inclinometer debugging assistant for preliminary angle monitoring and debugging. If you wish to directly access the inclinometer sensor, you can download the serial port debugging assistant via the sensor's communication protocol to connect and access it, enabling the sensor to be easily integrated into your system.

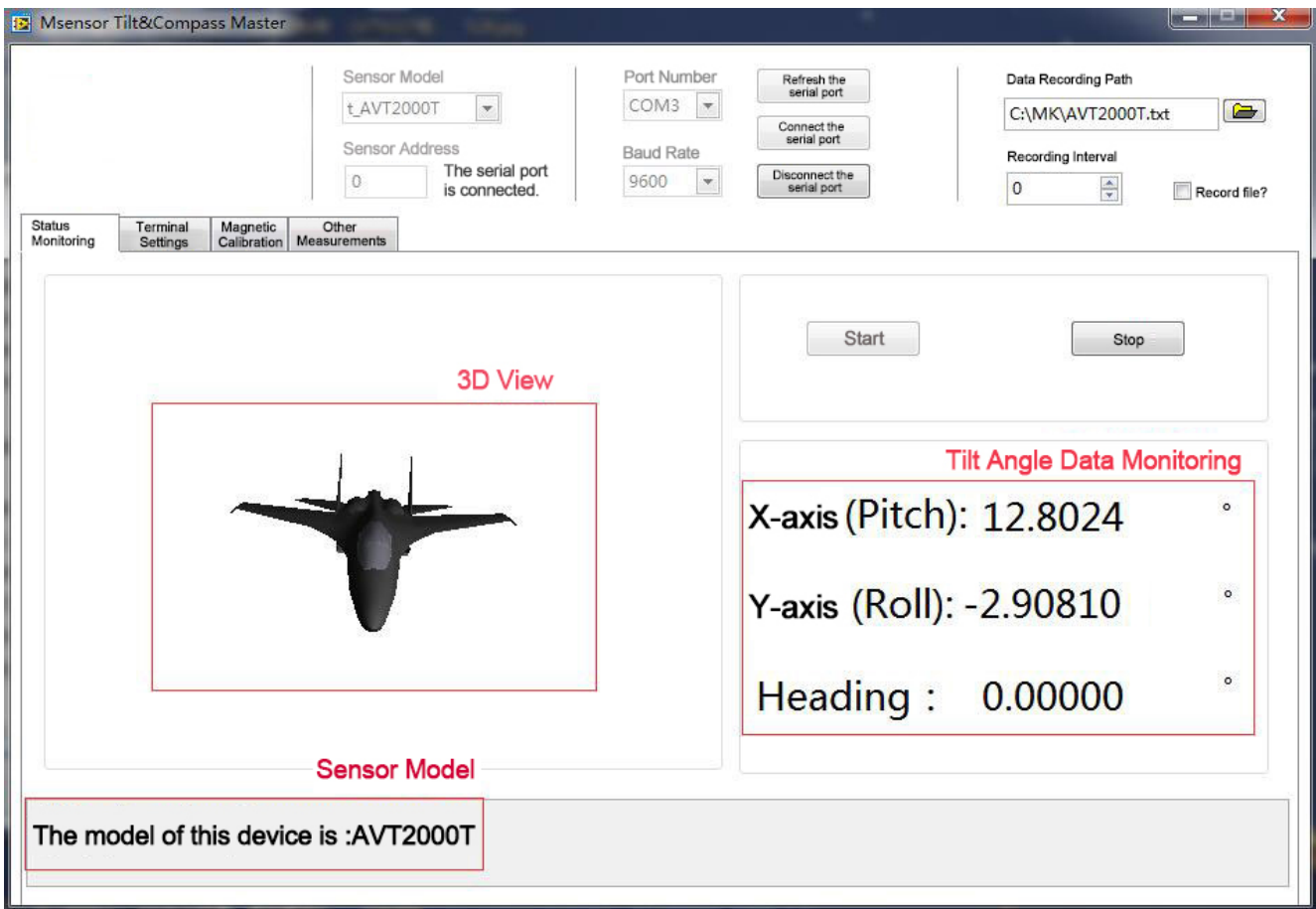

Inclinometer Calibration Assistant

Device Model: Select the corresponding product model.

Serial Port: Select the corresponding COM port for the device.

Device Address: Enter the current address code of the sensor. The factory default is 00. Baud

Rate: Select the current baud rate of the sensor. The factory default is 9600.

Status Monitoring: Connect the serial port, click Start, and begin data collection.

Status Settings: Configure the functional parameters of the sensor.

## Communication Protocol

**1 Data frame format:** (8 data bits, 1 stop bit, no parity, default rate 9600)

Identifier	Data length	Address code	Command	Data domain	Checksum
(1byte)	(1byte)	(1byte)	(1byte)		(1byte)
0x68					

Data format: Hexadecimal

Identifier: Fixed at 0x68

Data length: Length from data length to checksum (including checksum)

Address code: The address of the acquisition module, defaulting to 0x00.

Data field: The content and length vary depending on the command word.

Checksum: The sum of the data length, address code, command word, and data field, without considering carry (Note: When the command word or data field changes, the checksum will change. **When you modify the data field, please adjust the checksum accordingly.**)

## 2 Command Format

### 2.1 Reading the X-axis angle

**Send command:** 68 04 00 01 05

Identifier	Data length	Address code	Command	Data field	Checksum
(1byte)	(1byte)	(1byte)	(1byte)	(0byte)	(1byte)
0x68			0x01		

**Response command:**

Identifier	Data length	Address code	Command	Data field	Checksum
(1byte)	(1byte)	(1byte)	(1byte)	(4byte)	(1byte)
0x68			0x81	SSXX.YYYY	

Note: The data field is 3 bytes long and returns the angle value in compressed BCD code, where SS is the sign bit (00 positive, 10 negative), XX is a two-digit integer value, and YYYY is a four-digit decimal value. Data for other axes is the same. For example, 10 26 87 80 represents -26.878°.

### 2.2 Reading the Y-axis angle

**Send command:** 68 04 00 02 06

Identifier	Data length	Address code	Command	Data field	Checksum
(1byte)	(1byte)	(1byte)	(1byte)	(0byte)	(1byte)
0x68			0x02		

**Response command:**

Identifier	Data length	Address code	Command	Data field	Checksum
------------	-------------	--------------	---------	------------	----------

(1byte)	(1byte)	(1byte)	(1byte)	(4byte)	(1byte)
0x68			0x82	SSXX.YYYY	

## 2.3 Reading the X and Y axis angles

Send command: 68 04 00 04 08

Identifier	Data length	Address code	Command	Data field	Checksum
(1byte)	(1byte)	(1byte)	(1byte)	(0byte)	(1byte)
0x68			0x04		

Response command:

Identifier	Data length	Address code	Command	Data field	Checksum
(1byte)	(1byte)	(1byte)	(1byte)	(12byte)	(1byte)
0x68			0x84		

Note: The data field is a 12-byte return angle value, divided into three groups, each group is a symbol bit and three compressed BCD codes. They are x-axis angle, y-axis angle, and 0; see Instruction 2.1 for the parsing format, e.g.: X-axis: +2.0103°, Y-axis: -0.5132°.

**X-axis: +02.0103°, Y-axis: -00.5132°**

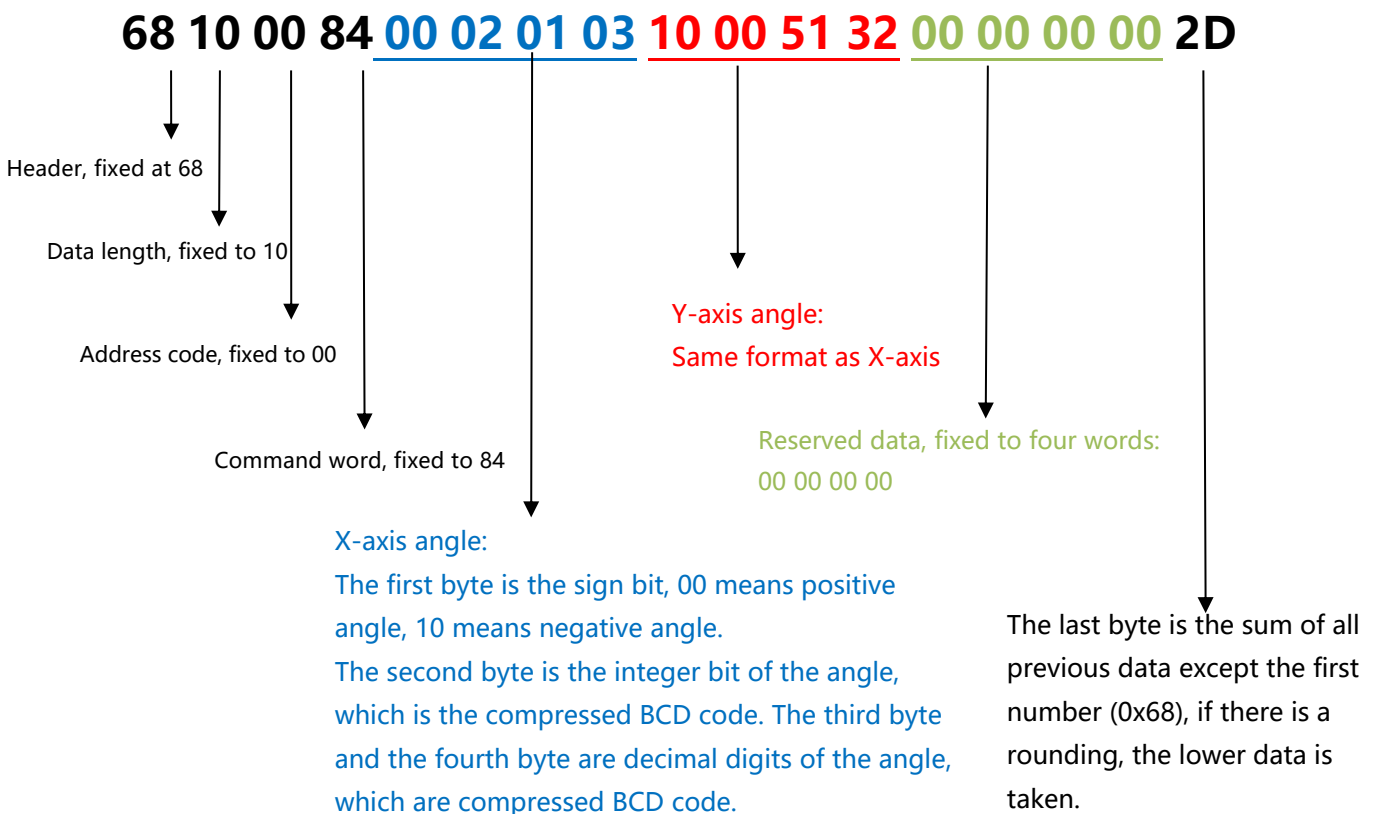

## 2.4 Set relative/absolute zero point

Send command: 68 05 00 05 00 0A

Identifier	Data length	Address code	Command	Data field	Checksum
(1byte)	(1byte)	(1byte)	(1byte)	(1byte)	(1byte)
0x68			0x05	0x00: Absolute zero point 0x01: Relative zero point	

Response command:

Identifier	Data length	Address code	Command	Data field	Checksum
(1byte)	(1byte)	(1byte)	(1byte)	(1byte)	(1byte)
0x68			0x85	0x00: Success 0xFF: Failure	

**Note:** The command is sent to the device via the I2C interface. The device will respond with a success or failure status. The device will respond with a success status if the command is successful. The device will respond with a failure status if the command is not successful.

## 2.5 Query relative/absolute zero point

Send command: 68 04 00 0D 11

Identifier	Data length	Address code	Command	Data field	Checksum
(1byte)	(1byte)	(1byte)	(1byte)	(0byte)	(1byte)
0x68			0x0D		

Response command:

Identifier	Data length	Address code	Command	Data field	Checksum
(1byte)	(1byte)	(1byte)	(1byte)	(1byte)	(1byte)
0x68			0x8D	0x00: Absolute zero point 0x01: Relative zero point	

## 2.6 Set communication speed

**Send command:** 68 05 00 0B 03 13

Identifier	Data length	Address code	Command	Data field	Checksum
(1byte)	(1byte)	(1byte)	(1byte)	(1byte)	(1byte)
0x68			0x0B		

**Response command:**

Identifier	Data length	Address code	Command	Data field	Checksum
(1byte)	(1byte)	(1byte)	(1byte)	(1byte)	(1byte)
0x68			0x8B	0x00: Success 0xFF: Failure	

Note: 0x00 represents 2400, 0x01 represents 4800, 0x02 represents 9600, 0x03 represents 19200, 0x04 represents 115200, 0x05 represents 14400, 0x06 represents 38400, 0x07 represents 57600, with **the default value being 0x02: 9600**. If the baud rate is set to 19200, the command is 68 05 00 0B 03 13, where 13 = 05 + 00 + 0B + 03. For other baud rates, follow the same pattern. After successfully changing the communication baud rate, a response command is sent at the original baud rate, and then the device's communication baud rate is immediately changed. Note: If high-frequency output is required, set the baud rate to 115200.

## 2.7 Set angle mode

**Send command:** 68 05 00 0C 00 11

Identifier	Data length	Address code	Command	Data field	Checksum
(1byte)	(1byte)	(1byte)	(1byte)	(1byte)	(1byte)
0x68			0x0C	0x00: Q&A format 0x01: 5Hz Data Rate 0x02: 15Hz Data Rate 0x03: 25Hz Data Rate 0x04: 35Hz Data Rate 0x05: 50Hz Data Rate	

\*The default output mode is 00; if the device is in non-response mode, there will be a 10-second idle time after each power-on restart during which no data will be sent. After 10 seconds, continuous data output mode will begin.

## Response command:

Identifier	Data length	Address code	Command	Data field	Checksum
(1byte)	(1byte)	(1byte)	(1byte)	(1byte)	(1byte)
0x68			0x8C	0x00: Success 0xFF: Failure	

Note: A 5Hz data rate means that data is automatically output 5 times per second, with other rates following the same principle. When using products with an RS485 interface, since the 485 interface operates in half-duplex mode, the product may be unable to effectively receive input commands while automatically outputting data. In such cases, you may need to repeat the command multiple times for the product to receive it. **Therefore, if you need to send commands to interact with the product while using a 485 interface product, it is recommended to set the product to operate in question-and-answer mode.** Additionally, when the product is set to automatic output mode, there will be no output for the first 10 seconds after power-on, during which the product can effectively receive external configuration commands.

## 2.8 Set module address

**Send command:** 68 05 00 0F 01 15

Identifier	Data length	Address code	Command	Data field	Checksum
(1byte)	(1byte)	(1byte)	(1byte)	(1byte)	(1byte)
0x68			0x0F	XX module address	

Note: The default address for the sensor is 00.

## Response command:

Identifier	Data length	Address code	Command	Data field	Checksum
(1byte)	(1byte)	(1byte)	(1byte)	(1byte)	(1byte)
0x68			0x8F	0x00: Success 0xFF: Failure	

1. If multiple sensors are connected to a bus, such as RS485, each sensor must be set to a different address to achieve separate control and response speeds.
2. If the new address is successfully changed, all subsequent commands and response data packets must use the new address code for the change to take effect. Otherwise, the sensor will not respond to the command.
3. XX Module addresses range from 00 to EF.

## 2.9 Query module address

**Send command:** 68 04 00 1F

Identifier	Data length	Address code	Command	Data field	Checksum
(1byte)	(1byte)	(1byte)	(1byte)	(0byte)	(0byte)
68	04	00	1F		

**Note:** The checksum bit is not considered when querying the module address.

**Response command:**

Identifier	Data length	Address code	Command	Data field	Checksum
(1byte)	(1byte)	(1byte)	(1byte)	(1byte)	(1byte)
0x68			0x1F		

## 2.10 update flash (save settings)

**Send command:** 68 04 00 0A 0E

Identifier	Data length	Address code	Command	Data field	Checksum
(1byte)	(1byte)	(1byte)	(1byte)	(0byte)	(1byte)
0x68			0x0A		

**Response command:**

Identifier	Data length	Address code	Command	Data field	Checksum
(1byte)	(1byte)	(1byte)	(1byte)	(1byte)	(1byte)
0x68			0x8A	0x00: Success 0xFF: Failure	

\*For various parameter settings, if the save settings command is not sent after the settings are completed, these settings will be lost after the power is turned off.

## 2.11 Restore factory settings

**Send command:** 68 04 00 0E 12

Identifier	Data length	Address code	Command	Data field	Checksum
(1byte)	(1byte)	(1byte)	(1byte)	(0byte)	(1byte)
0x68			0x0E		

**Response command:**

Identifier	Data length	Address code	Command	Data field	Checksum
(1byte)	(1byte)	(1byte)	(1byte)	(1byte)	(1byte)
0x68			0x8E	0x00: Success 0xFF: Failure	