

PRODUCT DEBUGGING SOFTWARE

1.DATA FRAME FORMAT:(8 bits date,1 bit stop,No check,Default baud rate 9600)

Identifier (1byte)	Date Length (1byte)	Address code (1byte)	Command word (1byte)	Date domain	Check sum (1byte)
68					

Date format:hexadecimal,
 Identifier:Fixed68H,
 Data length:From data length to check sum(including check sum) length,
 Address code:acquisition module addressDefault :00,
 Data field will vary with content and length of command word,
 Check sum:sum of Data length,Address code,Command word and data field, not include identifier.

2.COMMAND WORD ANALYSIS

Desc	Meaning/Example	Description
0X04	Read angle command at the same time E.g : 68 04 00 04 08	Data domain(0byte) No Data domain command
0X84	Sensor respond E.g: 68 0A 00 84 00 20 10 10 05 20 F3	Data domain (6byte) AA AB BB CC CD DD AA AB BB:3 character indicate X axis CC CD DD:3 character indicate Y axis Angle format analysis is as the same with X and Y axis The angle of the left example is X axis 020.1 deg, Y axis -05.2 degree
0X05	Setting relative/absolute ZERO : Can set the current angle to Zero degree, relative measurement, can also be set to absolute ex-factory zero, power off save. E.g: 68 05 00 05 00 0A	Data domain(1byte) 00: absolute ZERO 01: relative ZERO
0X85	Sensor answer reply command E.g: 68 05 00 85 00 8A	Data domain(1byte) Data domain in the number means the sensor response results 00: successfully FF: failure
0X0B	Setting communication rate E.g: 68 05 00 0B 03 13 The command setting is effective after power off then restart (power off with save function)	Data domain(1byte)default value is :9600. Baud rate: 00: 2400 01: 4800 02: 9600 03: 19200 04: 38400 04: 115200
0X8B	Sensor answer reply command E.G:68 05 00 8B 00 90	Data domain(1byte) Data domain in the number means the sensor response results 00: Success FF: Failure
0X0C	Setting sensor output mode Response mode:Need upper computer send reading angle command , the sensor answer thecorresponding angle. Automatic output mode:The sensor with power on can Automatically output angle , output frequency is 20HZ . (Power off with save function) E.g: 68 05 00 0C 00 11	Data domain(1byte)factory default value:00 00: Answer reply mode 01: 5Hz automatical output mode 02: 10Hz automatical output mode 03: 15Hz automatical output mode 04: 20Hz automatical output mode
0X8C	The sensor answer reply command E.g: 68 05 00 8C 00 91	Data domain(1byte) Data domain in the number means the sensor response results 00: Success FF: Failure
0X0F	Setting module address command The sensor default address is 00; 1>such as a plurality of sensor to be connected with a bus cable ; E.g RS485.requires each sensor is set to a different address, in order to achieve control and response angle . 2>If successfully changed the new address, follow all of the commands and responding Packet address code has to switch to the new address code which already changed then to be effective, otherwise the sensor will not respond to commands. (power off with save function) E.g: 68 05 00 0F 01 15 Setting the address to 01 68 05 FF 0F 00 13 Use the common addre	Data domain (1byte)XX Module address Address from 00 to EF range Note: All products have a common address :FF, If forget the address what has been set during operation , can use FF address to operate the product can still normally respond
0X8F	The sensor answer reply command E.g: 68 05 00 8F 00 94	Data domain(1byte). Data domain in the number means the sensor response results 00: Success FF: Failure
0X0D	Query relative/absolute ZERO Used to query the sensor current ZERO mode is relative ZERO or absolute ZERO E.g : 68 04 00 0D 11	Data domain(0byte) No data domain commands
0X8D	The sensor answer reply command E.g:68 05 00 8D 00 92	Data domain (1byte). Data domain in the number means the sensor response results 00: Absolute ZERO 01: Relative ZERO



CE CERTIFICATION: ATSAHE181129003
 APPEARANCE PATENT : ZL 201830752891.5



www.such.com

sales@such.com

+86 773 280900

Global Shipping

INCLINOMETER | TILT SWITCH | DIGITAL INCLINOMETER | ELECTRONIC COMPASS ACCELEROMETER | GYROSCOPETHE SYSTEM | INERTIAL MEASUREMENT UNIT ATTITUDE AZIMUTH COMBINATION SYSTEM | GYRO SYSTEM | GPS POSITIONING SYSTEM

DESCRIPTION

MCA416/426T series tilt sensor is a new type of low-cost full-attitude tilt angle measurement product. It adopts the latest anti-interference platform design, integrates new micro-mechanical sensing units, has wide temperature working performance, superior anti-vibration performance, long-term stable and reliable operation, and effective working life of up to 10 years.

The product adopts a non-contact principle to measure the inclination angle of an object, and the real-time inclination angle is calculated by measuring the component generated by the gravity of the earth through the internal capacitive micro-mechanical unit; the product is simple and convenient to install, only needs to be fixed on the object to be measured, does not need a fixed shaft and a rotating shaft, has a plurality of installation modes, meets the measurement requirements of customers, is an engineering mechanical vehicle, an agricultural machine, And other industrial equipment ideal accessories.

FEATURES

- Resolution:0.1°
- Output: RS232/RS485/TTL
- Six installation methods
- Power supply: 9~36V
- Zero set function
- Work temperature:-40~+85°C
- IP67
- High anti-shock>3500g

SYSTEM DIAGRAM

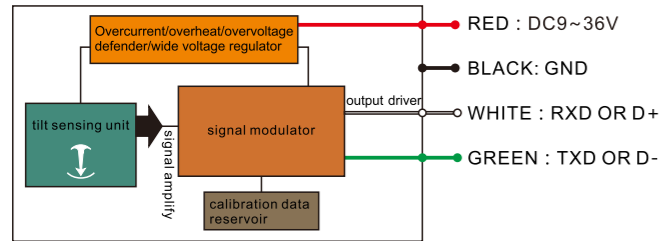

SIZE

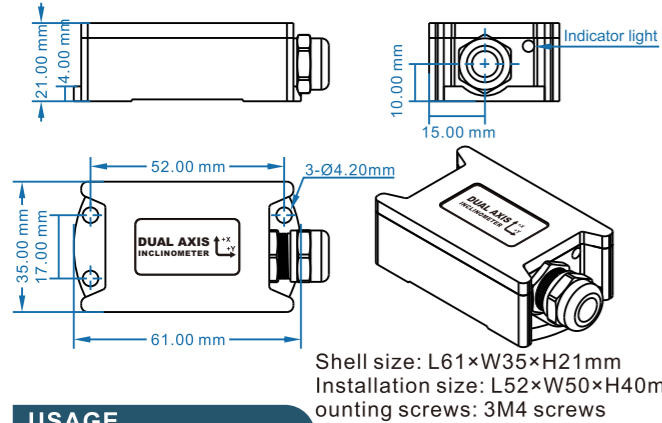

USAGE

1. The tilt sensor measures the inclination angle of the object by sensing the principle of gravity of the earth, and try to ensure that the direction of the induction axis of the sensor is parallel to the direction of the inclination axis of the measured object during installation, so as to achieve the best measurement accuracy. The sensor and the measured surface must be tight, flat and stable. If the installation surface is uneven, it is easy to cause the sensor measure with angle error.

2. The tilt sensor can be installed and measured arbitrarily on six surfaces. After installation, to set ZERO through the relative ZERO command. (At the same time, set the current installation mode. The set value is stored in the internal memory of the product. After zero setting, the product will work with the current position as zero.)

3. The tilt sensor has IP67 protection, rain or strong spray water will not affect the work of the internal devices. Please do not use it in water for a long time, so as to avoid damage to the internal circuit of the product. The manufacturer will provide paid maintenance services for the damage caused by this.

4. After the tilt sensor installation, please pay attention not to short circuit the signal line and the positive pole of the power line when wiring, so as not to burn out the output circuit. Because the negative pole of the signal of this product is shared with the negative pole of the power supply, please connect the negative pole of the signal of the acquisition end with the negative pole of the power supply of this product.

APPLICATION

- Agricultural machinery
- Lifting machinery
- Crane
- Aerial platform
- Solar tracking system
- Medical equipment
- Electric vehicle control

PARAMETERS

MCA416&426T	CONDITIONS	PARAMETER	UNIT
Resolution		0.1	°
Accuracy	25°C	±0.2	°
Response Time		0.05	S
Temperatu Drift	-40 ~ 85°C	±0.5	°
Output Load		>500 ohm	
Working Time		98000 hours/time(no fault)	
Insulation Resistance		>100 ohm	
Anti-shock		10grms、10~1000Hz	
Impact Resistance		100g@11ms,3 Axial Direction (Half Sinusoid)	
Weight		≤200g(Including 1 meter standard cable)	
Certificate		CE ; APPEARANCE PATENT	
Quality System		IATF16949:2016 GJB9001C-2017 standard	

ORDER GUIDE

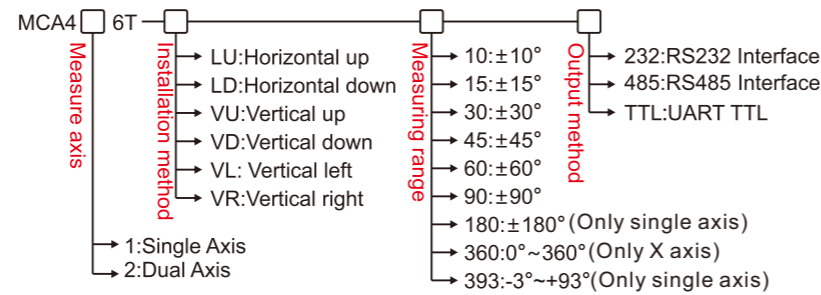

E.g: MCA416T-LU-10: Indicates Single-axis, Horizontal Up Installation Method, ±10° Measure range.

Note: The measuring range 0°~360° is limited to X-axis (clockwise rotation), and the installation method only support "VU" optional.

CONNECTION



INSTALLATION WAY

► HORIZONTAL MEASUREMENT INSTALLATION DIRECTION

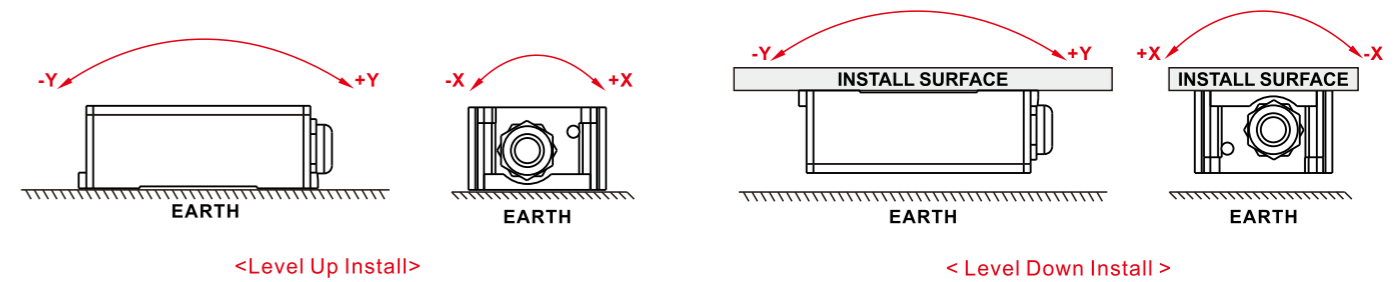

► VERTICAL MEASUREMENT INSTALLATION DIRECTION

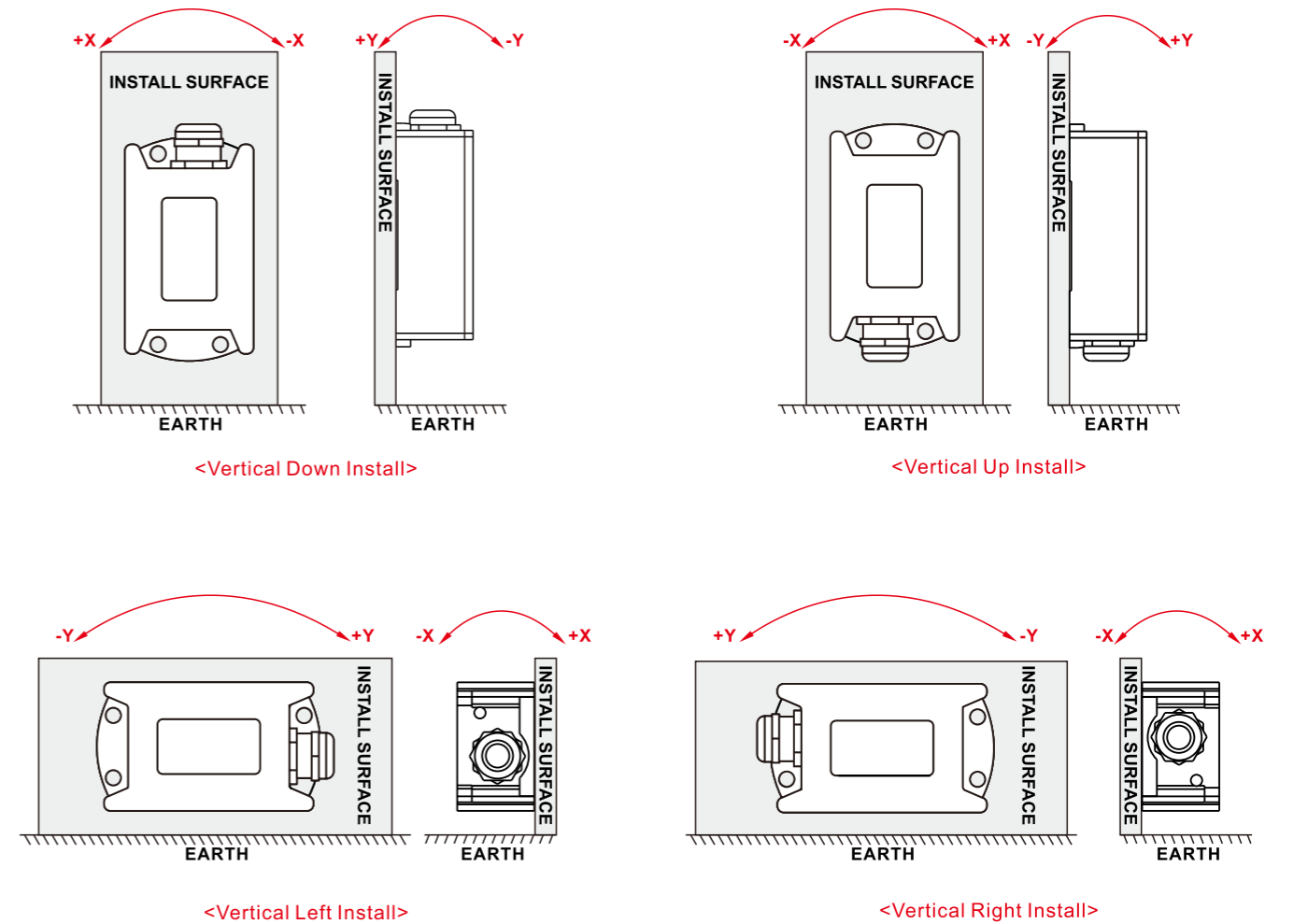

Remarks: The factory default installation is horizontal upward, the user can sets the corresponding installation method according to needs, please refer to Article 2 of the operating instructions, and make the corresponding settings.