

SUCH

SCA118T/SCA128T

CE FC ROHS

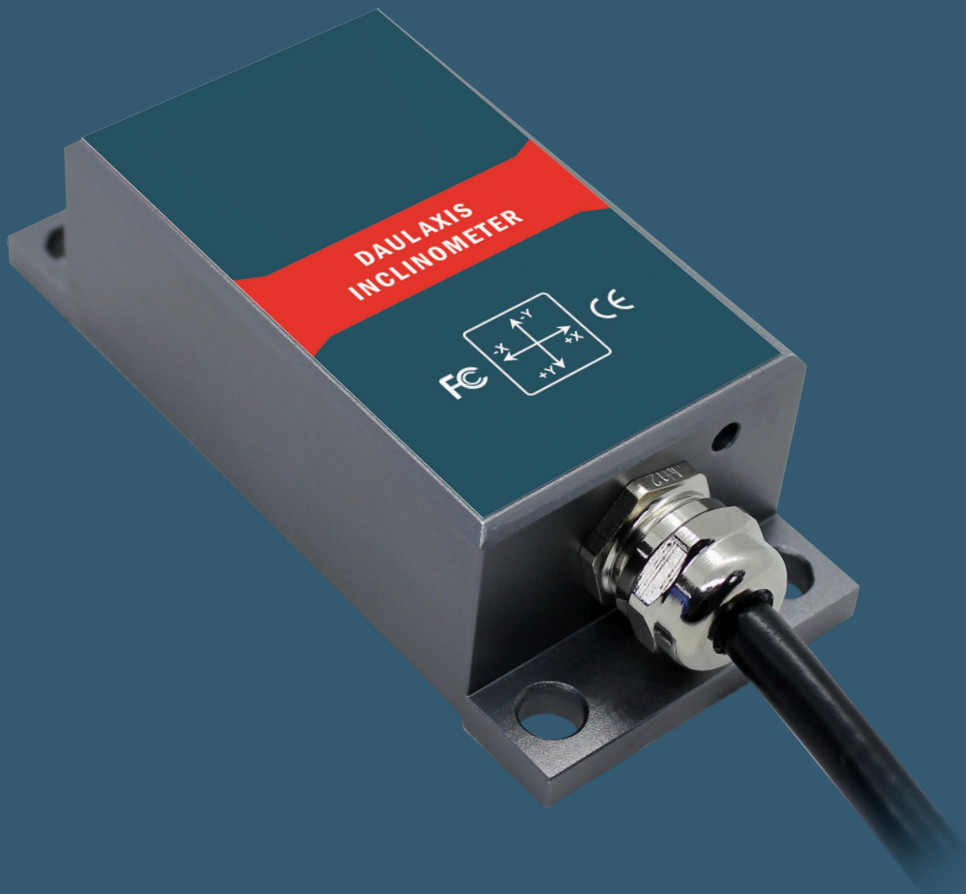

V1.8

CURRENT TYPE SINGLE/DUAL AXIS INCLINOMETER

SCA118T/SCA128T

Technical Manual



► INTRODUCTION

SCA118T/SCA128T is a standard industrial output type single/dual axis inclinometer with a standard current output of 4-20mA, which can transmit up to 2000 meters over long distances. The output signal has strong anti-interference and is professionally applied to construction machinery equipment working in harsh environments. The product is produced using the latest MEMS sensor production process, and the temperature error and nonlinear error are accurately compensated and corrected. The highest accuracy in a small range can reach 0.02 ° (for more accuracy indicators, please refer to the product performance table), high accuracy, Small size, high packaging technology, good ability to withstand shock and vibration. The product has built-in anti-RF and anti-electromagnetic interference circuits, which is especially suitable for underground trenchless machinery and other harsh industrial environments. In addition to having better technical parameters than ordinary products in the market, the product also uses various measures such as high-end application-level MCUs, three-proof PCB boards, imported cables, and wide-temperature shielded metal shells to improve the reliability and stability of the products. Industrial grade.

► MAIN FEATURE

- ★ Single/dual Axis Inclinometer
- ★ Accuracy: 0.03°
- ★ Output current 4~20mA
- ★ IP67 protection class
- ★ Resolution: 0.01°
- ★ Measuring Range :±1~±180° optional
- ★ Wide voltage input: 9~36V
- ★ Wide temperature working: -40~+85°C
- ★ Highly anti-vibration performance >2000g
- ★ Size: L94×W40×H26mm

► APPLICATION

- ★ Leveling of construction vehicles
- ★ Safety protection of high-altitude platforms
- ★ Underground drilling rig attitude navigation
- ★ Direction measurement based on inclination
- ★ Mining machinery and oil drilling equipment
- ★ Inclination monitoring of geological equipment
- ★ Medical equipment angle control
- ★ Shield pipe jacking application
- ★ Equipment level control
- ★ Monitoring of bridges and Dadian



► PARAMETERS

SCA118/SCA128T	CONDITION	PARAMETER					UNIT
Measure range		±10	±30	±60	±90	±180	°
Measure axis		X / X Y	X / X Y	X / X Y	X / X Y	X	Axis
Zero output	0° output	12	12	12	12	12	mA
Resolution		0.01	0.01	0.02	0.03	0.05	°
Measure accuracy	@25°C	0.03	0.05	0.06	0.08	0.1	°
Long term stability		0.05	0.05	0.05	0.05	0.05	°
Zero Temp coefficient	-40 ~ 85°C	±0.00 6	±0.006	±0.006	±0.006	±0.006	°/°C
Sensitivity temp-coeffi	-40 ~ 85°C	≤100	≤100	≤100	≤100	≤100	ppm/ °C
Power-on start time		0.5	0.5	0.5	0.5	0.5	S
Response frequency	20Hz						
EMC	According to EN61000 and GBT17626c						
MTBF	≥98000 hours/times						
Insulation Resistance	≥100 MΩ						
Impact resistance	100g@11ms、 3 Axis Direction (Half Sinusoid)						
Anti-vibration	10grms、 10 ~ 1000Hz						
Protection grade	IP67						
Cables	Standard as 1-meter length, wear-resistant, oil-proof, wide temperature, shielded cable 4 * 0.4mm ²						
Weight	≤220g (including 1 meter cable)						

► ELECTRICAL PARAMETERS

PARAMETERS	CONDITION	MIN	TYPICAL		MAX	UNIT
Power supply voltage	Standard	9	12	24	36	V
Working current			50			mA
Output overload	Resistive		400		1000	Ω
Working temp		-40			+85	°C
Store temp.		-40			+85	°C

KEY WORDS

Resolution: It refers to the smallest change value that the sensor can detect and distinguish in the measurement range.

Measure accuracy: Refers to the combined error of linearity, repeatability, hysteresis, zero deviation, and horizontal axis error of the sensor under normal temperature conditions.

Long-term stability: refers to the deviation between the maximum value and the minimum value of the sensor under normal temperature conditions after a year of long-term work.

Response time: It refers to the time required for the sensor output to reach the standard value when the sensor changes angle once.

► ORDER INFORMATION

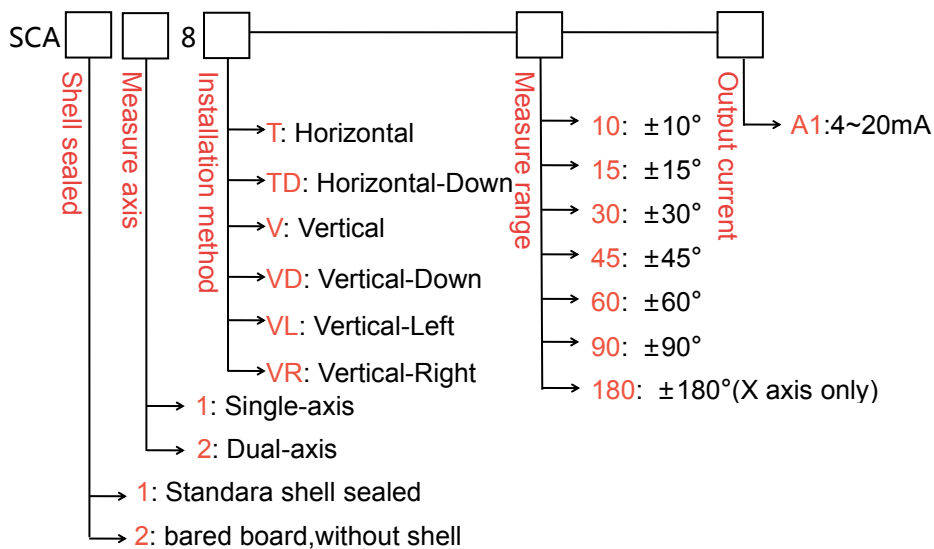

E.g: SCA118T-10-A1: Standara shell sealed / Single axis / Horizontal / $\pm 10^\circ$ measure range / 4~20mA .

► MECHANICAL PARAMETERS

- Connectors: 1m lead cable (customized)
- Protection glass: IP67
- Enclosure material : Aluminum Oxide
- Installation : 4*M6 screws

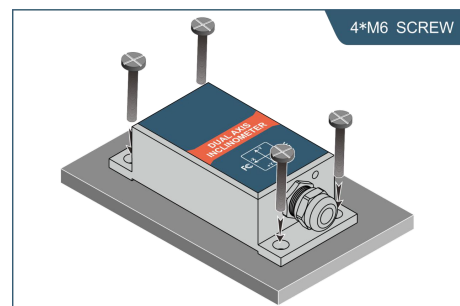

▶ WORKING PRINCIPLE

Adopt imported core control unit and apply the principle of capacitive micro-pendulum. Using the principle of earth's gravity, when the tilting unit tilts, the earth's gravity will produce a gravitational component on the corresponding pendulum, and the corresponding electric capacity will change. By amplifying and filtering the electric capacity, the inclination angle is obtained after conversion.

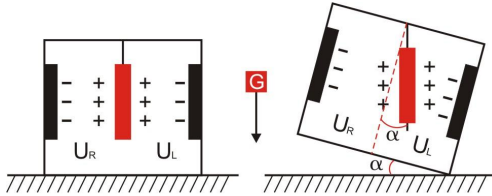

U_R, U_L respectively is the pendulum left plate and the right plate corresponding to their respective voltage between the electrodes, when the tilt sensor is tilted, U_R, U_L will change according to certain rules, so $f(U_R, U_L)$ on the inclination of α function:

$$\alpha = f(U_R, U_L)$$

▶ TYPICAL PERFORMANCE CHART

1 : Input and output characteristics :

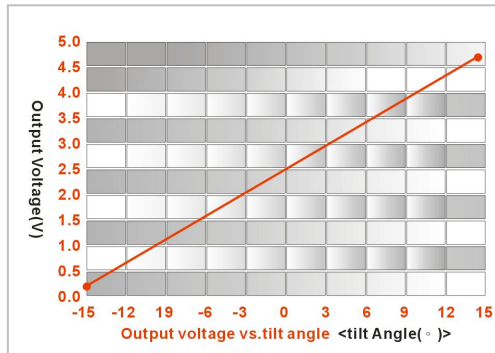

2 : Temperature characteristic graph :

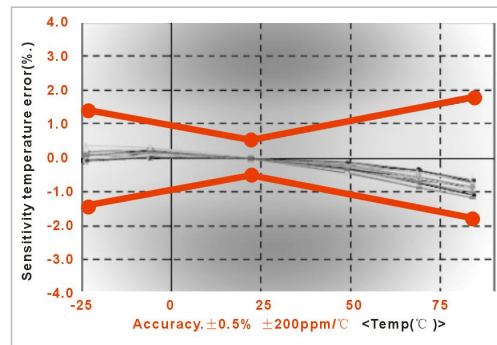

▶ ANGLE CALCULATION FORMULA

Angle = (output current - zero position current) \div angle sensitivity
 Angle sensitivity = output current range \div angle measurement range
 Example: SCA118T-30-A1 ($\pm 30^\circ$ measurement range 16mA output current range)
 Angle sensitivity = $16 \div 60 = 0.266666 \text{ mA} / ^\circ$

▶ ELECTRICAL CONNECTION

Shell package wiring definition

Line color function	RED	BLACK	WHITE	GREEN
	Vcc9~36V Power supply Power positive	GND Power negative	Out X X Axis output current	Out Y Y Axis output current

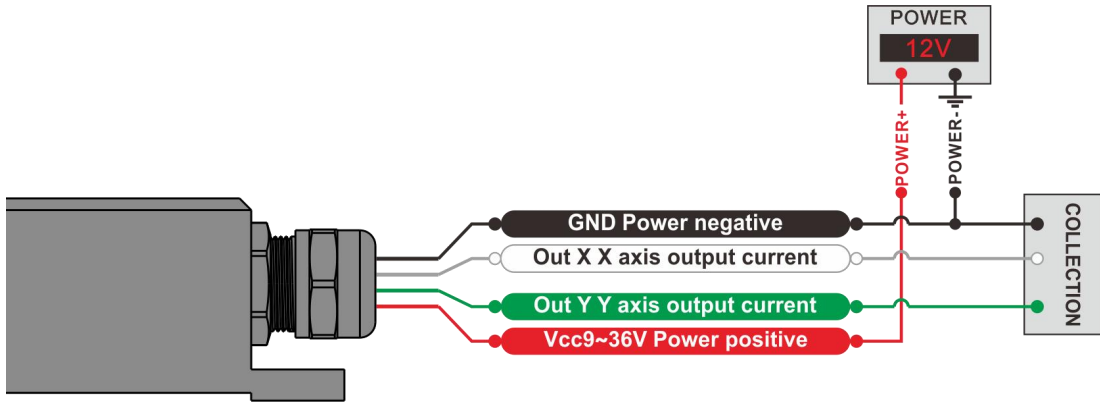

Board wiring definition

Line color function	RED	BLACK	YELLOW	WHITE
	Vcc9~36V Power supply Power positive	GND Power negative	Out X X Axis output current	Out Y Y Axis output current

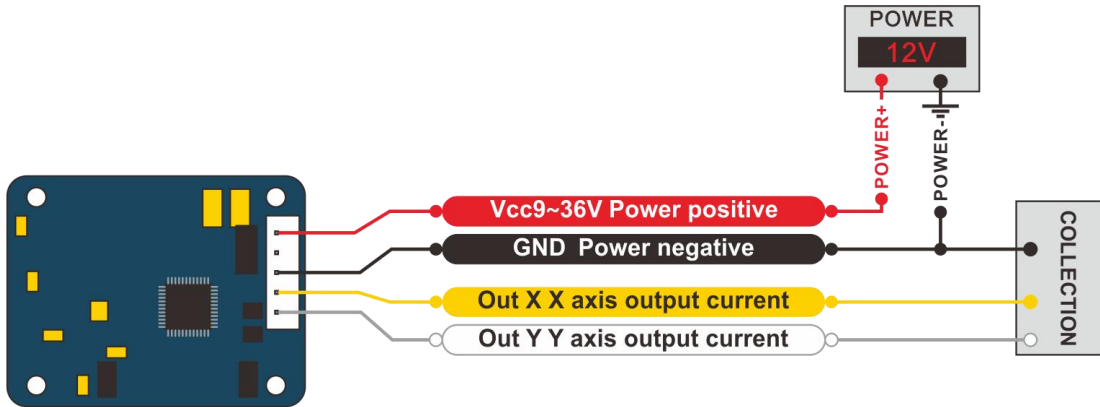

► SIZE

PCBA BOARD SIZE

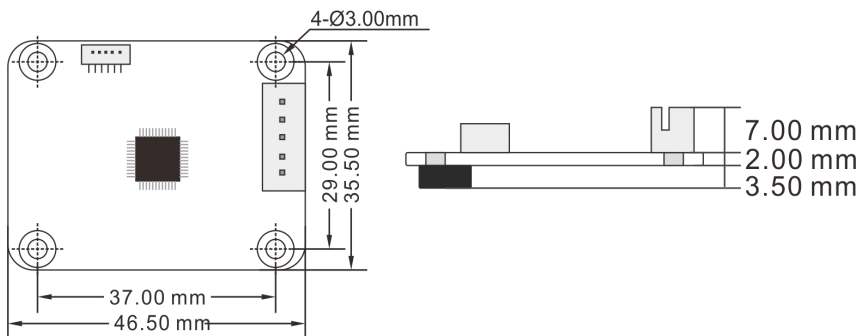

PCBA board size: L46.5×W35.5×H12.5mm

Installation size: L37×W29×H2mm

Outting screws: 4 M3 screws

SHELL SIZE

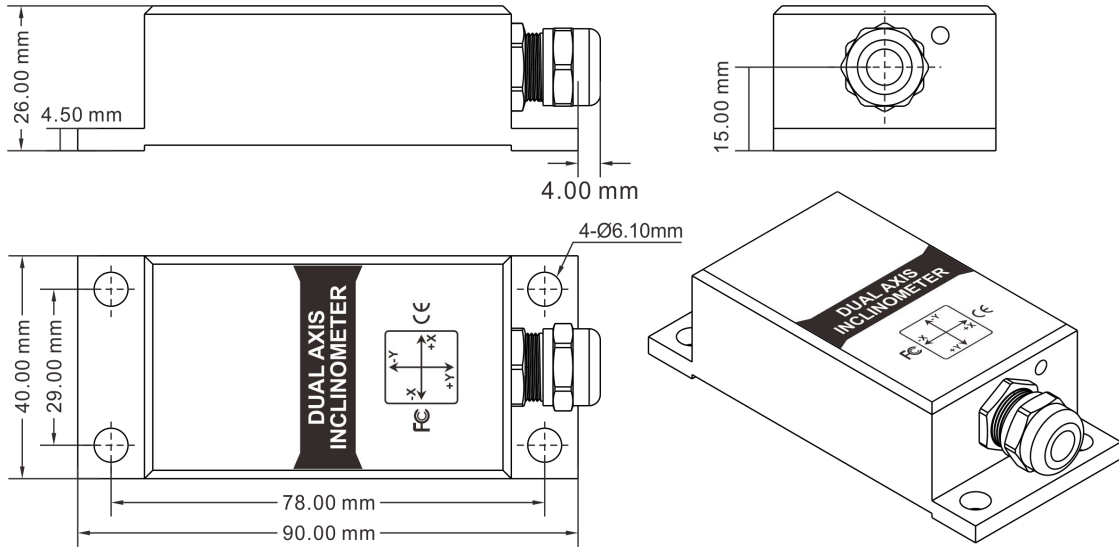

Shell size: L90×W40×H26mm
 Installation size: L78×W29×H4.5mm
 Mounting screws: 4 M6 screws

► INSTALLATION PRECAUTIONS

Please install the tilt sensor according to the correct method. Improper installation will cause measurement error. Pay attention to the first "surface" and the second "line":

- 1) The mounting surface of the sensor and the measured surface must be tight, flat and stable. The unevenness of the mounting surface is easy to cause the angle error of the sensor measurement.
- 2) The axis of the sensor and the axis to be measured must be parallel, and the angle between the two axes should be avoided as much as possible.

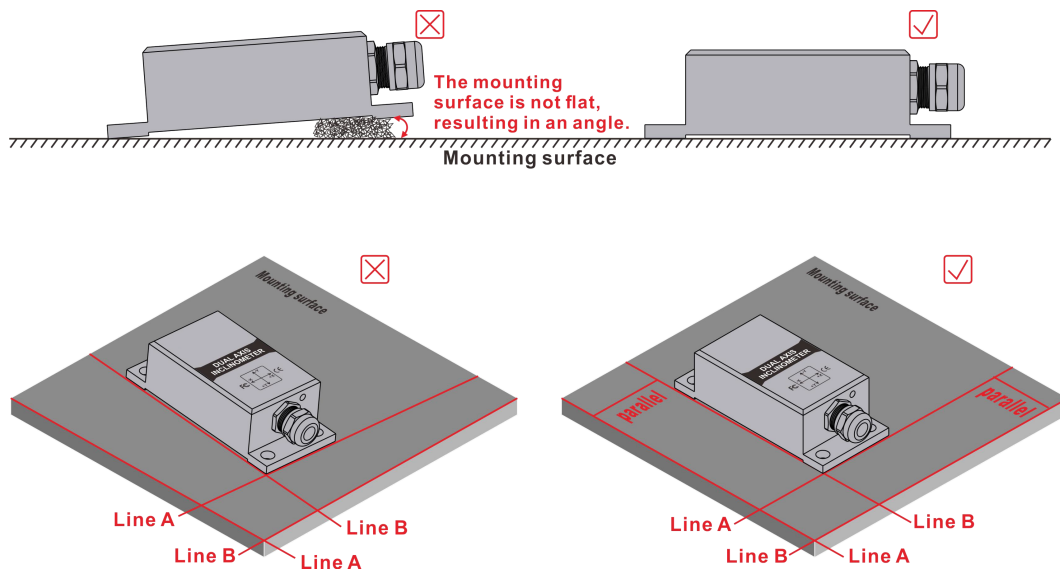

► INSTALLATION DIRECTION

During installation, keep the sensor mounting surface parallel to the target surface to be measured, and reduce the impact of dynamics and acceleration on the sensor. This product can be installed horizontally or vertically, please refer to the following diagram for the installation method:

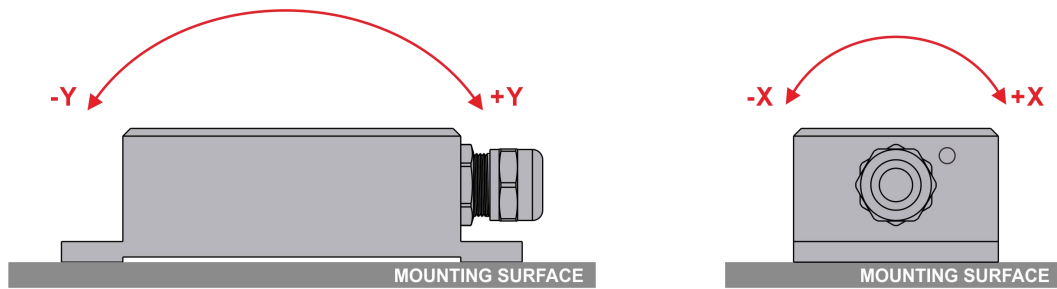

Horizontal installation

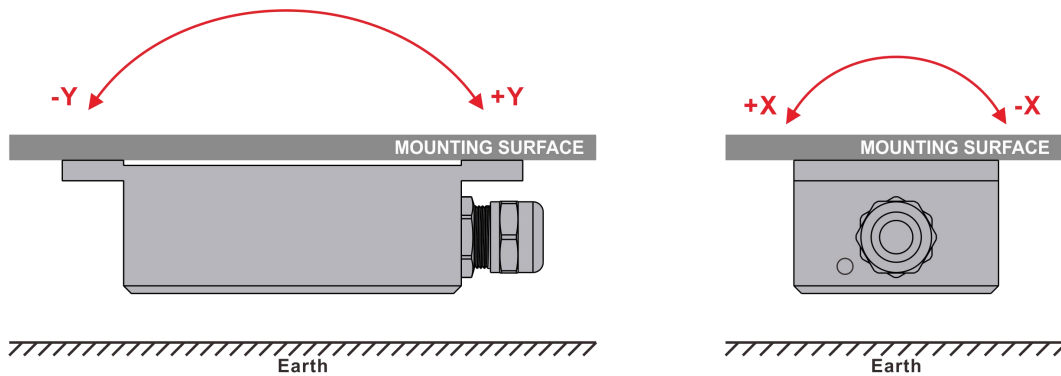

Horizontal-down installation

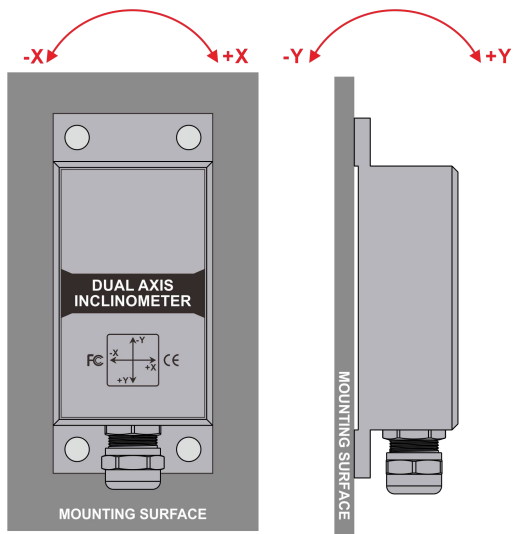

Vertical installation

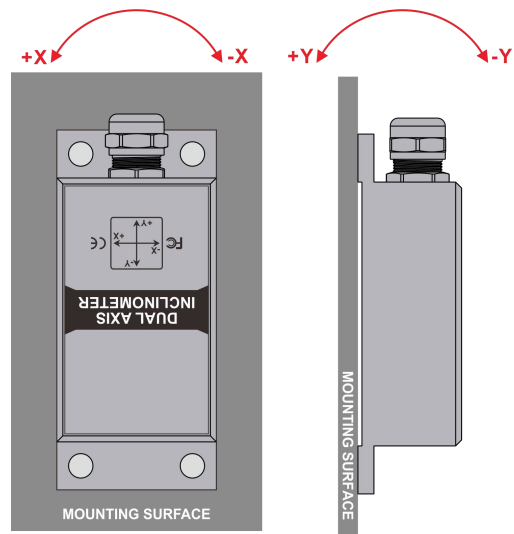

Vertical-down installation

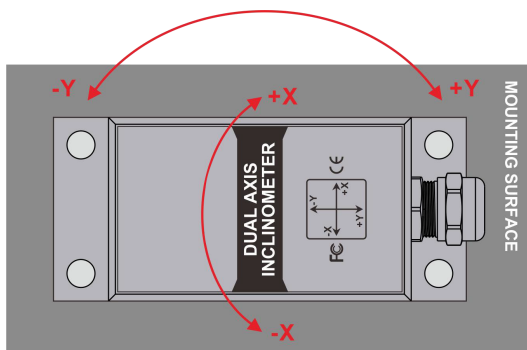

Vertical-left installation

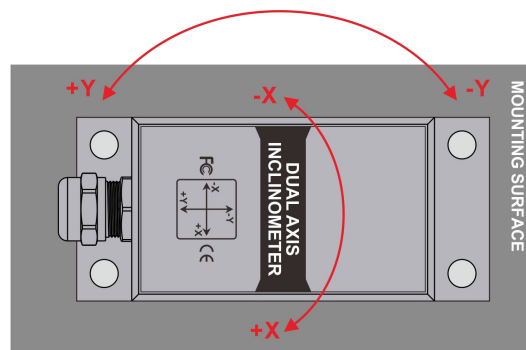

Vertical-right installation