

**SUCH**

# Water Quality Dissolved Oxygen Sensor User Manual



## User Notes

- Please read this manual in detail before using it and save it for reference.
- Please abide by the operating procedures and matters needing attention in this manual.
- When receiving the instrument, please carefully open the package and check whether the instrument and accessories are damaged by shipping. If any damage is found, please inform the manufacturer and distributor immediately and keep the package for return for processing.
- When the instrument fails, please do not repair it on your own, please contact the maintenance department of the manufacturer directly.

## Content

User Notes .....	1
I 、 Operational Principle .....	4
II 、 Technical performance and specifications .....	5
1. Technical parameter .....	5
2. Dimensional drawing .....	5
III 、 Installation and electrical connection .....	6
1. Install .....	6
2. Electrical connection .....	6
IV 、 Maintenance .....	6
1. Maintenance schedule and methodology .....	6
2. Frequently questions .....	7
3. Calibration of sensors .....	8
4. Points for attention .....	8
V 、 Quality and service .....	8
1. Quality assurance .....	8
2. Spare parts and spare parts .....	9
3. After-sales service commitment .....	9
Appendix data communication .....	9

## I 、 Operational Principle

RDO-106 integrated on-line fluorescence dissolved oxygen sensor is designed and fabricated based on the quenching principle of excited fluorescence by specific substances in physics. When the excitation light is shone on the fluorescent material on the surface of the fluorescent film head, the fluorescent material is excited and emits fluorescence. The quenching time of fluorescence is affected by the concentration of oxygen molecules on the surface of the fluorescent film head. By detecting the phase difference between fluorescence and excitation light and comparing with the internal calibration curve, the concentration of oxygen molecules can be calculated, and the final value can be output after temperature and salinity compensation.

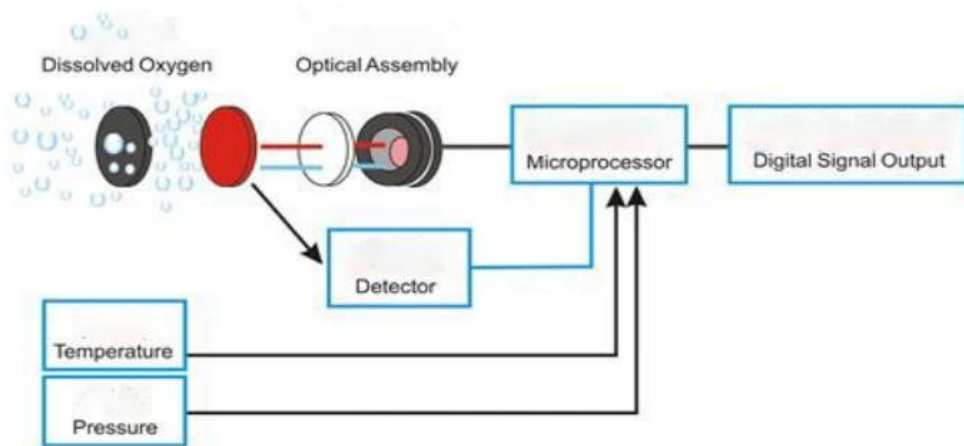

- No electrolyte is required and will not be polarized.
- No oxygen consumption, not affected by flow rate.
- Built-in temperature sensor, automatic temperature compensation.
- Built-in salinity compensation, flexible parameter setting
- Free from interference by chemicals such as sulfides
- Small drift, rapid reaction, more accurate measurement.
- Long service cycle, lower cost of use.
- Simple replacement of fluorescent cap.
- Rs-485 interface, Modbus/RTU protocol.
- Low power consumption, anti-interference.

## II、 Technical performance and specifications

### 1. Technical parameter

<b>Model</b>	<b>RDO-106</b>
<b>Measuring principle</b>	Fluorescence method
<b>Range ability</b>	0~20mg/L (0 - 200% saturation, 25°C)
<b>Resolution ratio</b>	0.01mg/L, 0.1°C
<b>Precision</b>	±2%, ±0.3°C
<b>Temperature compensation</b>	Automatic temperature compensation (Pt1000)
<b>Output mode</b>	RS-485(Modbus/RTU)
<b>Working conditions</b>	0~50°C、≤0.2MPa
<b>Storage temperature</b>	-5~65°C
<b>Installation mode</b>	Immersion mounting
<b>Cable length</b>	5 meters, other lengths customizable
<b>Power dissipation</b>	0.2W@12V
<b>Source</b>	12-24VDC
<b>levels of protection</b>	IP68
<b>Calibration</b>	Two-point calibration
<b>Fluorescent cap life</b>	Guaranteed use for one year (under normal use)
<b>Sensor shell material</b>	POM and 316L stainless steel

### 2. Dimensional drawing

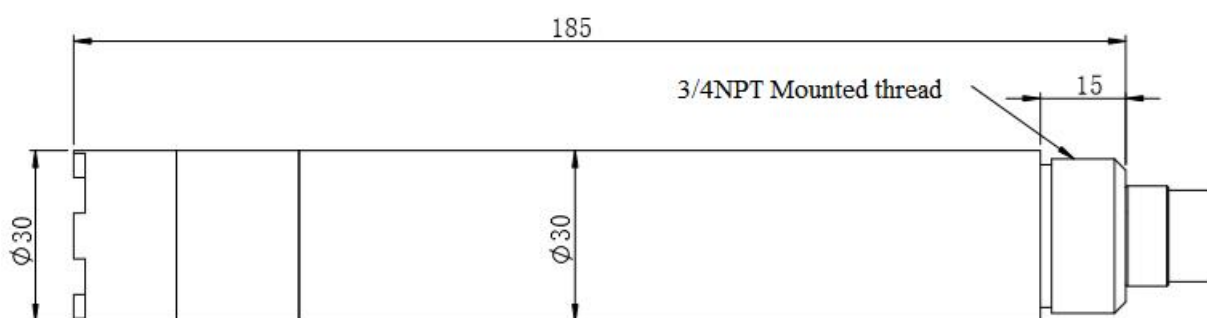

**Note:**The sensor connector is m16-5 core waterproof connector male.

## III、 Installation and electrical connection

### 1. Install

The sensor shall be installed fixedly below the liquid level. The installation and use shall avoid collision or scraping against the surface of the fluorescent film head. The fluorescent film head part shall avoid being attached by the bottom sediment. Remove the rubber cover when use.

### 2. Electrical connection

- Red wire-power cord (12~24V)
- Black wire-ground wire (GND)
- Blue Line-485A
- White Line-485B

Check wiring sequence carefully before power on to avoid unnecessary losses caused by wiring errors.

Cable specification: Considering that the cable is immersed in water (including sea water) for a long time or exposed to the air, all the wiring points are required to do waterproof treatment, the user cable should has certain corrosion resistance.

## IV、 Maintenance

### 1. Maintenance schedule and methodology

#### 1.1 Maintenance schedule

Different from the dissolved oxygen probe technology of electrochemical principle, the fluorescence dissolved oxygen probe does not consume oxygen and does not need to be cleaned frequently (except when it is used in viscous liquid).

Maintenance task	Recommended maintenance frequency
Cleaning sensor	Wash every 30 days
Check for damage to sensors and fluorescent caps	Check every 30 days
Replace the fluorescent cap	Replace it once a year
Calibrate sensors (if required by the competent authority)	According to the maintenance schedule required by the competent department

Note: The maintenance frequency in the above table is only recommended, and the maintenance personnel shall clean the sensor according to the actual use of the sensor; however, the replacement frequency of the fluorescent cap is recommended once a year.

## 1.2 Maintenance method

a) Sensor outer surface: clean the outer surface of the sensor with tap water, if there is still debris residue, wipe with wet soft cloth, for some stubborn dirt, you can add some household washing liquid to tap water to clean.

b) Surface of fluorescent film head: If there is dirt on the surface of fluorescent film head, please rinse with clean water or wipe gently with a soft cloth. Pay attention to the intensity of cleaning to avoid causing scratches in the measuring area and affecting the measurement accuracy.

c) Inside the fluorescent film head: it is generally unnecessary to clean. If water vapor or dust enters into the fluorescent film head, the cleaning steps are as follows:

- Screw down the fluorescent film head;
- Rinse the inner surface of the fluorescent film head and the optical window of the sensor.
- For oily dirt, you can use household cleaning solution;
- Gently dry the water with a clean flannelless cloth and let dry;
- Reinstall the fluorescent film head.

d) Check the cables of the sensor: there should be no damage to the skin and root of the cables; Terminals should not be submerged in water; When the sensor is normally installed, the cable should not be tensioned, otherwise the internal wire of the cable will easily break and the sensor cannot work normally.

e) Check whether the casing of the sensor is damaged by corrosion or other causes.

f) Daily storage of fluorescent film head: When not in use, a rubber protective cover with a wet sponge should be covered to keep the surface of the measuring area of fluorescent film head wet. If the surface of the measuring area of the sensor fluorescent film head is chronically dry, measurement error or data instability will occur, and it shall be soaked in water for 48 hours before use.

## 2. Frequently questions

Wrong	Probable cause	Solution
The operating interface cannot connect or does not display the measurement results	Error connecting controller to cable	Reconnect the controller and cable
	Cable failure	Please contact us.
	The fluorescent cap is not tightened or damaged	Refit and tighten the fluorescent cap or replace the fluorescent cap.
The measured value is too high, too low, or the numerical value remains unstable.	The outer surface of the fluorescent cap is attached to the outer object	Clean the outer surface of the fluorescent film head and agitate the film head during measurement.
	The fluorescent cap was damaged	Replace the fluorescent cap

	The fluorescent cap has exceeded its service life	
Temperature measurements change slowly.	The temperature measuring area (stainless steel housing) is attached to the exterior	Gently brush the attachment with a soft brush

### 3. Calibration of sensors

a) Zero calibration

Weighing 5 g of sodium sulfite by a balance, adding 95mL of water into a 250-mL measuring cylinder, pouring the water into a beaker, adding the sodium sulfite which has been weighed, stirring with a glass rod, dissolving, and obtaining a solution of 5% sodium sulfite, putting the sensor in a solution, And the zero point calibration is carried out after the three-minute numerical stability is stable. Refer to the Appendix to the instructions

b) Slope calibration

The sensor probe is placed in air saturated water and the slope is calibrated after 3 minutes of numerical stability. The instructions refer to the appendix.

c) Preparation of air saturated water: add 2/3 volume fresh distilled water to the constant temperature water bath to float the porous plastic sheet on the water surface (see figure as below). At the same time, the bubbler (air pump) is used to aerate the water continuously for more than 1 hour, stop aeration, and get air saturated water after 20 minutes or so. Put the sensor into the water and calibrate the slope after the numerical value is stable.

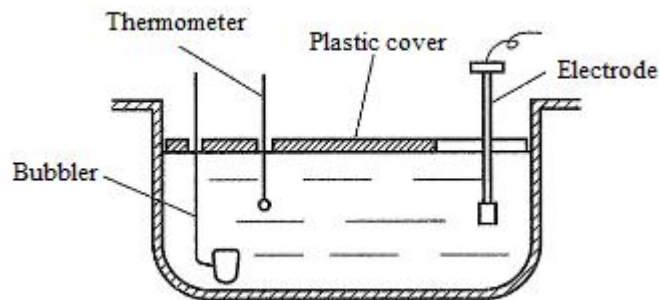

Note: as an option, slope calibration can also be performed in water-saturated air. Put the sensor in a calibration bottle with a small amount of water (the probe is higher than the water surface 2-3mm) to ensure that the sensor film cap remains wet but has no water droplets, and the calibration slope is calibrated after 3 minutes of numerical stability.

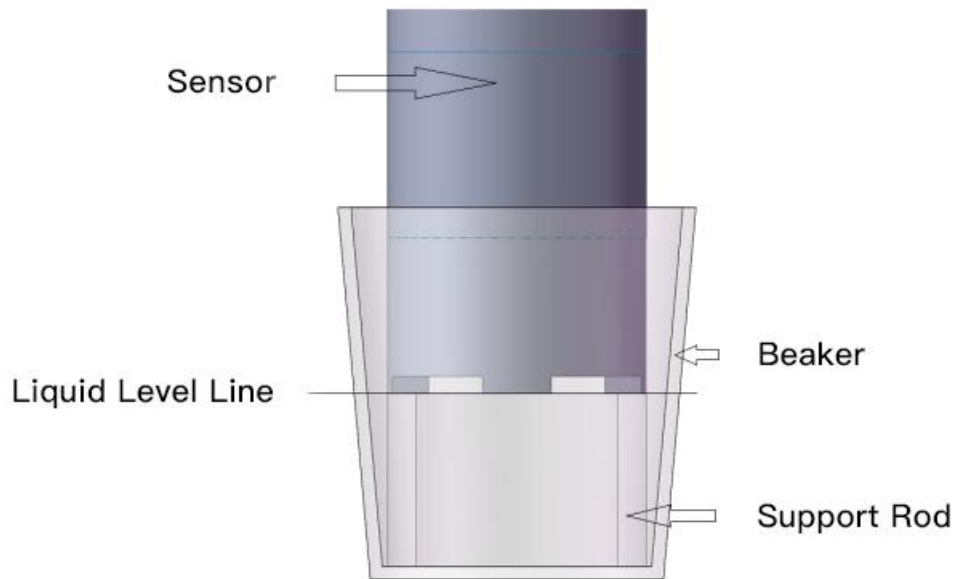

#### 4. Points for attention

- Avoid sun exposure to the inner surface of the fluorescent cap.
- Please don't touch the fluorescent film with your hands.
- Measuring and calibrating the surface of fluorescent film to avoid attaching bubbles.
- Avoid directly applying any mechanical stress (pressure, scratches, etc.) to the fluorescent film in use.

### V、Quality and service

#### 1. Quality assurance

- The quality inspection department has a standard inspection procedure, with advanced and complete detection equipment and means, and according to the procedure inspection, the product is subjected to 72-hour aging experiment and stability experiment, so that a non-conforming product is not allowed to leave the factory.

- The consignee shall refund directly the product batches with a failure rate of 2%, and all expenses incurred shall be borne by the supplier. Consider the standard reference to the product description provided by the supplier.

- Ensure the quantity of goods and the speed of shipment.

#### 2. Spare parts and spare parts

This product includes:

- 1 sensor
- 1 cable 5 meters

#### 3. After-sales service commitment

The company provides after-sales service for this machine within one year from the date of sale, but

does not include the damage caused by improper use. If you need to repair or adjust, please send it back, but the freight must be borne by yourself, and it is necessary to make sure that the packing is good to avoid damage in transit. We will repair the damage of the instrument free of charge.

## Appendix data communication

### 1. Data format

The default data format for Modbus communication is: 9600, n, 8, 1 (baud rate 9600bps, 1 start bit, 8 data bits, no check, 1 stop bit).

### 2. Information frame format (xx stands for one byte)

a) Read data instruction frame

<b>05</b>	03	xx	xx	xx	xx	xx	xx
Address	FC	Register start address		Number of registers		CRC check code (low bytes in front)	

b) Read data response frame

<b>05</b>	03	xx	xx.....xx	xx	xx
Address	FC	Number of bytes	Response data	CRC check code (low bytes in front)	

c) Write data instruction frame

<b>05</b>	06	xx	xx	xx	xx	xx	xx
Address	FC	Register address		Read-in data	CRC check code (low bytes in front)		

d) Data response frame

<b>05</b>	06	xx	xx	xx	xx	xx	xx
Address	FC	Register address		Read-in data	CRC check code (low bytes before)		

### 3. Register address

Register address	Name	Instruction	Number of registers	Access method
40001 (0x0000)	Measured value+temperature	Four double-byte integers, measured value, measured value decimal , temperature value, decimal places,	4 (8 bytes)	read
40005 (0x0004)	Dissolved oxygen saturation (0-200%)	Two double-byte integers, saturation values and decimal places, respectively.	2 (4 bytes)	read
44097 (0x1000)	Zero calibration	Calibrated in anoxic water, writing data 0; readout data zero offset.	1 (2 bytes)	Write / read
44101 (0x1004)	Slope calibration	Calibrate in air-saturated water, write data to 0, read data to slope value × 1000.	1 (2 bytes)	Write / read
44113 (0x1010)	temperature correction	In the solution, the written data is the actual temperature value × 10, and the readout data is the temperature calibration offset × 10.	1(2 bytes))	Write / read
44129 (0x1020)	Salinity compensation	The read / write data is salt value (PSU) × 10, which is used for salinity compensation, and the factory default is 0, no salinity compensation. Write values in the range of 0 to 500, corresponding to 0 to 50.0 PSU.	1 (2 bytes)	Write / read
48195 (0x2002)	Sensor address	The default is 5, and the data range is 1-255.	1 (2 bytes)	Write / read

48196 (0x2003)	Baud Rate	The default is 9600. 0 -- 9600, 1 -- 19200.	1 ( 2 bytes )	Write/Read
48225 (0x2020)	Reset sensor	The calibration value is restored to default by writing 0. Note: The sensor must be recalibrated after resetting before it can be used.	1 ( 2 bytes )	write

#### 4. Command example

a) Measurement instructions:

Function: Get the dissolved oxygen value and temperature measured by the sensor; the unit of dissolved oxygen is mg/L, and the unit of temperature is °C.

Request frame: 05 03 00 00 00 04 45 8D

Response frame: 05 03 08 01 02 00 02 00 B0 00 01 DB 0C

Reading example:

Dissolved oxygen value	Temperature value
01 02 00 02	00 B0 00 01

For example: the dissolved oxygen value 01 02 represents the dissolved oxygen value in hexadecimal reading, 00 02 represents the dissolved oxygen value with 2 decimal points, and the converted decimal value is 2.58.

The temperature value 00 B0 represents the hexadecimal reading temperature value, 00 01 represents the temperature value with 1 decimal point, and the converted decimal value is 17.6.

b) Calibration instructions:

Zero point calibration

Function: Set the dissolved oxygen zero point calibration value of the sensor;

Request frame: 05 06 10 00 00 00 8C 8E

Response frame: 05 06 10 00 00 00 8C 8E

slope calibration

Function: Set the dissolved oxygen slope calibration value of the sensor; here the slope value calibration is performed in air-saturated water.

Request frame: 05 06 10 04 00 00 CD 4F

Response frame: 05 06 10 04 00 00 CD 4F

c) Set device ID address:

Function: Set the MODBUS device address of the sensor;

Change the device address 05 to 01. The example is as follows:

Request frame: 05 06 20 02 00 01 E3 8E

Response frame: 05 06 20 02 00 01 E3 8E

d) Salinity compensation instructions:

Function: Set the sensor's salinity compensation;

Measure water with a salinity of 35.0 PSU and add salinity compensation. The example is as follows:

Request frame: 05 06 10 20 01 5E 0D 2C

Response frame: 05 06 10 20 01 5E 0D 2C

## 5. Error response

If the sensor does not execute the upper computer command correctly, the following format information is returned:

Definition	Address	Function code	Code	CRC check
Data	ADDR	COM+80H	xx	CRC 16
Number of bytes	1	1	1	2

- a) CODE: 01 – Functional code error  
03 – Data error
- b) COM: Received function code